

# AQI 12

Ultra-compact, vented sub-bass system

## features

- ▶ Ultra-compact, architecturally friendly styling
- ▶ Direct radiating 12" (300mm) driver with 3" (75mm) voice coil
- ▶ Generously sized, low noise ports
- ▶ Alternative textured paint colours to order

## applications

- ▶ Clubs, bars and restaurants
- ▶ Theatres
- ▶ Live sound in places of worship
- ▶ AV presentations



architectural

The Martin Audio AQI 12 is a direct radiating sub-bass in an ultra-compact heavily braced, vented enclosure. It features a very efficient 12" (300mm) long-throw bass driver with a high power 3" (75mm) voice coil and generously sized low frequency ports for low noise, high power operation.

The AQI 12's ultra-compact size makes it an ideal partner for Martin Audio AQ Series full-range loudspeakers where space is at a premium or where the subwoofers need to be hidden.

A Martin Audio AQX Electronic Controller is available to provide subwoofer crossover, limiter and trim functions.

Century Point, Halifax Road, Cressex Business Park,  
High Wycombe, Buckinghamshire HP12 3SL, England.  
Telephone: +44 (0)1494 535312 Facsimile: +44 (0)1494 438669  
E-mail: [info@martin-audio.com](mailto:info@martin-audio.com)  
All information is Copyright © 2005 Martin Audio Ltd.



# AQ112

Ultra-compact, vented sub-bass system

overall dimensions

architectural

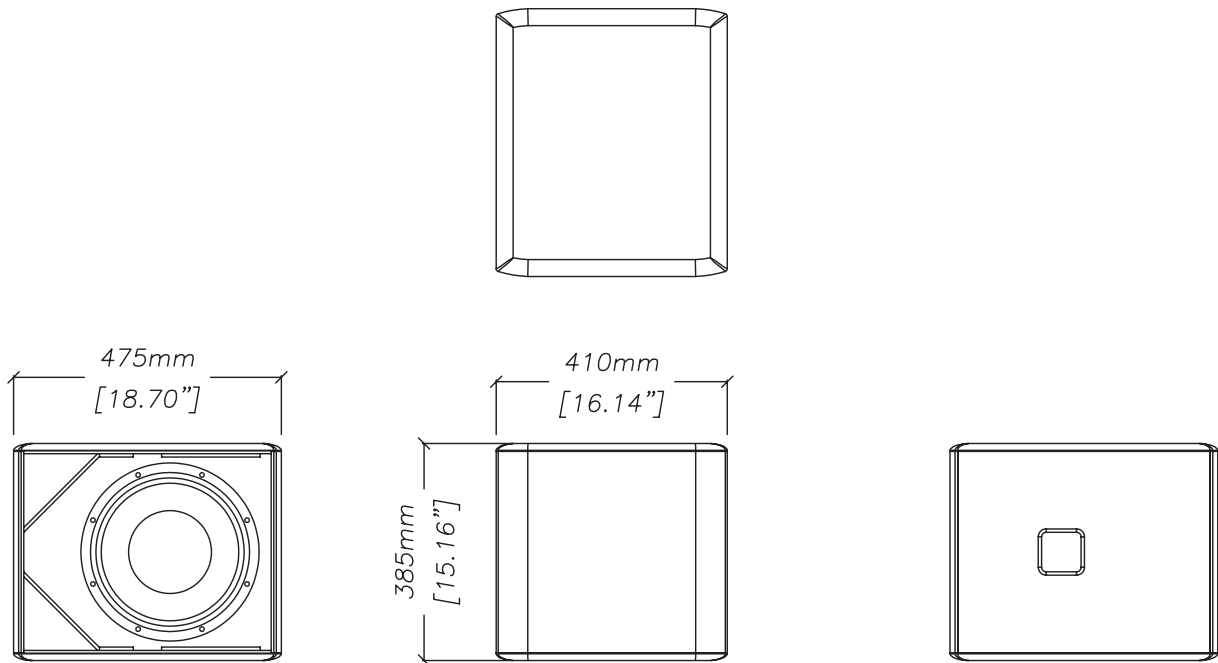

AQ112

Century Point, Halifax Road, Cressex Business Park,  
High Wycombe, Buckinghamshire HP12 3SL, England.  
Telephone: +44 (0)1494 535312 Facsimile: +44 (0)1494 438669  
E-mail: [info@martin-audio.com](mailto:info@martin-audio.com)  
All information is Copyright © 2005 Martin Audio Ltd.



# AQI 12

Ultra-compact, vented sub-bass system

## technical specifications

TYPE	Ultra-compact, vented sub-bass
FREQUENCY RESPONSE (1)	48Hz-150Hz $\pm$ 3dB
DRIVERS	12" (300mm)/3" (75mm) voice coil LF driver
RATED POWER (2)	400W AES, 1600W peak
RECOMMENDED AMPLIFIER	400-800W into 4 ohms
SENSITIVITY (6), (3)	96dB (open space), 102dB (half space)
MAXIMUM SPL (calculated @ 1m)	120dB continuous, 126dB peak (open space) 126dB continuous, 132dB peak (half space)
NOMINAL IMPEDANCE	8 ohms
CROSSOVER	120Hz active (via AQX controller)
ENCLOSURE	52 litre, braced 18mm MDF
FINISH	Textured light grey paint
PROTECTIVE GRILLE	Light grey perforated steel
CONNECTORS	Low profile 20 amp push-lock
FITTINGS	
OPTIONS	Passive low pass filter
DIMENSIONS	(W) 475mm x (H) 385mm x (D) 410mm (W) 18.7ins x (H) 15.2ins x (D) 16.2ins
WEIGHT	21.5kg (47lbs)

## architectural and engineering specifications

The loudspeaker system shall be of the ultra-compact sub-bass type consisting of one 12" (300mm) 3" (75mm) voice coil direct radiating reflex loaded low frequency transducer in an internally braced MDF enclosure. The loudspeaker shall be operated with a separate electronic controller for dedicated sub-bass use.

Performance of the loudspeaker system with its electronic controller shall meet or exceed the following criteria:

Frequency response measured 1 metre on axis shall be 48Hz-150Hz  $\pm$  3dB.

Power handling shall be 400W AES, 1600W peak.

Rated impedance shall be 8 ohms.

Maximum SPL measured at 1 metre on axis shall be 126dB continuous, 132dB peak.

Dimensions (W) 475mm x (H) 385mm x (D) 410mm (18.7ins x 15.2ins x 16.2ins).

Weight 21.5kg (47lbs).

The loudspeaker system shall be the Martin Audio AQI 12.

### Notes

- (1) Measured on-axis in half space at 2 metres, then referred to 1 metre.
- (2) AES Standard ANSI S4.26-1984.
- (3) Measured in half space at 2 metres with 1 watt input, using band limited pink noise, then referred to 1 metre.
- (4) Measured in half space at 2 metres using band limited pink noise, then referred to 1 metre.
- (5) Measured on-axis in open ( $4\pi$ ) space at 2 metres, then referred to 1 metre.
- (6) Measured in open ( $4\pi$ ) space at 2 metres with 1 watt input, using band limited pink noise, then referred to 1 metre.
- (7) Measured in open ( $4\pi$ ) space at 2 metres using band limited pink noise, then referred to 1 metre.

### Trade Descriptions Act

Due to Martin Audio's policy of continuing improvement, we reserve the right to alter these specifications without prior notice. Martin Audio is committed to refining state of the art sound reinforcement, combining in-depth product and field applications research with advanced manufacturing techniques. Every Martin Audio product is built to the highest manufacturing standards and rigorously tested to ensure that it meets the performance criteria specified in the design.

Century Point, Halifax Road, Cressex Business Park,  
High Wycombe, Buckinghamshire HP12 3SL, England.  
Telephone: +44 (0)1494 535312 Facsimile: +44 (0)1494 438669  
E-mail: [info@martin-audio.com](mailto:info@martin-audio.com)  
All information is Copyright © 2005 Martin Audio Ltd.

