

Beatline 10

Compact, full-range system

features

- ▶ Wide 90° x 50° dispersion
- ▶ Rotatable HF horn
- ▶ Architecturally friendly styling
- ▶ 1st & 2nd fix wall and ceiling brackets available

applications

- ▶ KTV bars



Beatline

The Martin Audio Beatline10 is a two-way passive loudspeaker designed to provide high sound pressure levels from a compact, architecturally friendly, heavily braced, vented enclosure. It features a 10" (250mm) long-throw, direct radiating bass driver with a 2.5" (63mm) voice coil, and a 1.4" (35mm) diaphragm, 1" (25mm) exit compression driver coupled to a true constant directivity HF horn.

The Beatline10's high power-to-size ratio makes it ideal for medium throw applications in clubs, bars, AV presentations, places of worship, museums, foyers, sports venues and exhibition centres. Its high output sound pressure level makes it suitable for distributed live sound applications in theatres and concert halls and its sonic accuracy makes it appropriate for medium scale post production applications.

The Beatline10 features a generously sized high frequency horn and a high order crossover for superior pattern control down into the low midrange and smooth off-axis characteristics. The Beatline10 is housed in a heavily braced MDF enclosure and fitted with a flush, acoustically transparent steel grille. The enclosure is fitted with six M8 inserts for fitting AQWB8, AQCS, or AQCL brackets to allow for horizontal or vertical mounting, plus two additional M8 inserts for either a safety point or fitting the AQFB Flying Bracket.

Century Point, Halifax Road, Cressex Business Park,
High Wycombe, Buckinghamshire HP12 3SL, England.
Telephone: +44 (0)1494 535312 Facsimile: +44 (0)1494 438669
E-mail: info@martin-audio.com
All information is Copyright © 2011 Martin Audio Ltd.



Beatline 10

Compact, full-range system

polar plots - 1/3rd 8ve, 6dB/div

Beatline

Horizontal

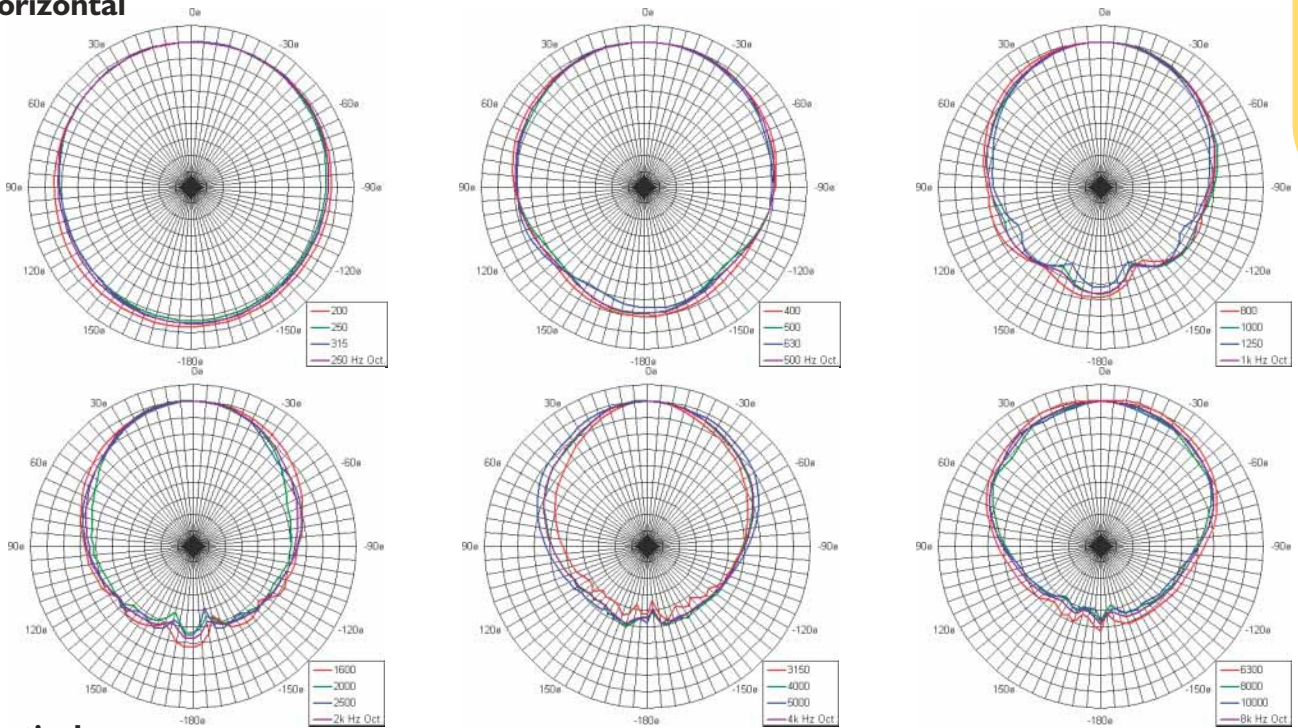

Vertical

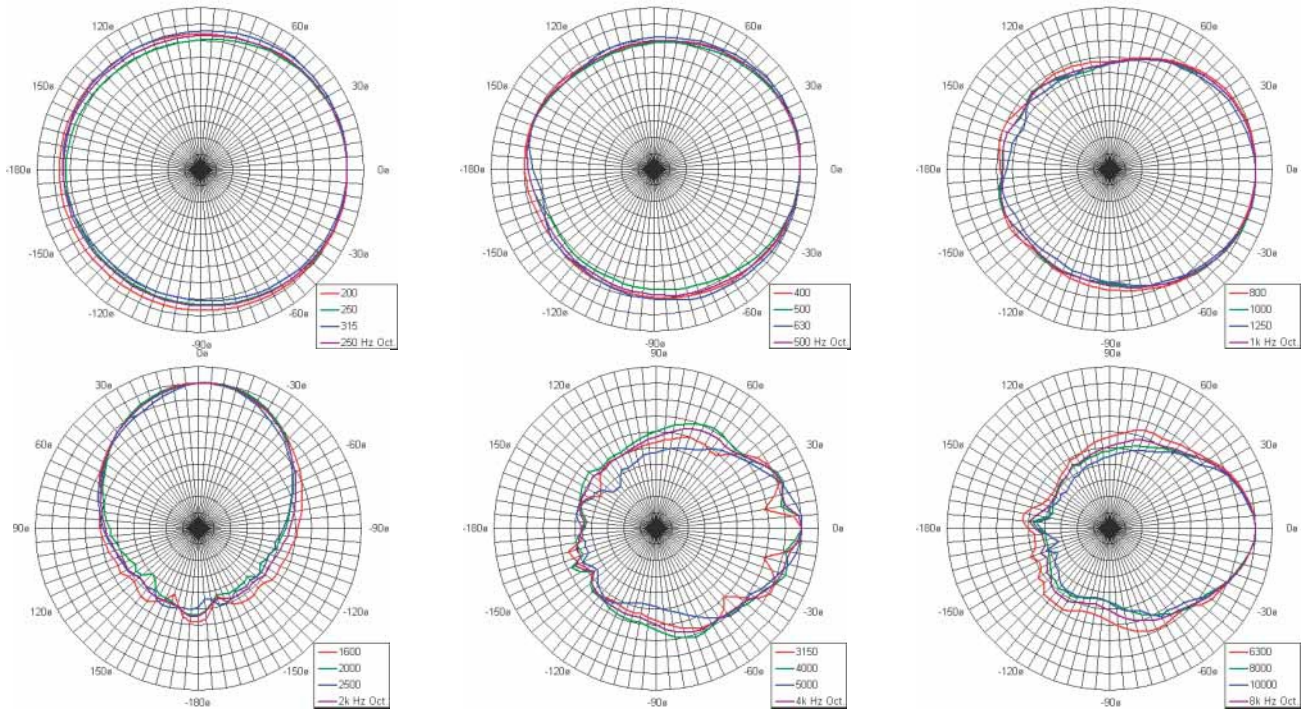

Century Point, Halifax Road, Cressex Business Park,
High Wycombe, Buckinghamshire HP12 3SL, England.
Telephone: +44 (0)1494 535312 Facsimile: +44 (0)1494 438669
E-mail: info@martin-audio.com
All information is Copyright © 2011 Martin Audio Ltd.



Beatline 10

Compact, full-range system

frequency responses

Beatline

Horizontal (symmetrical)

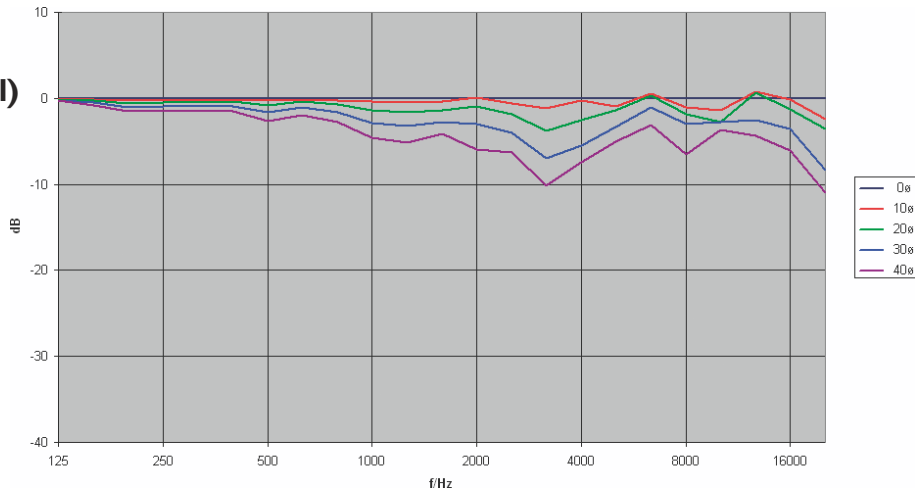

Vertical -(up)

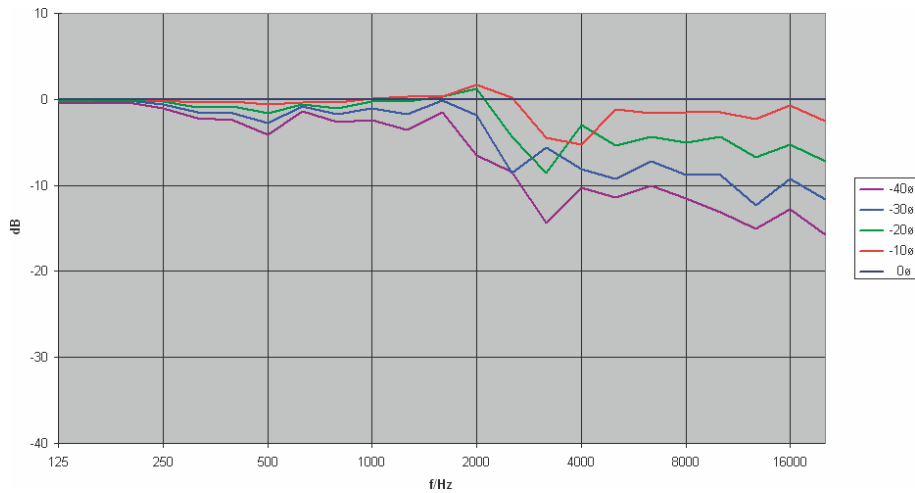

Vertical +(down)

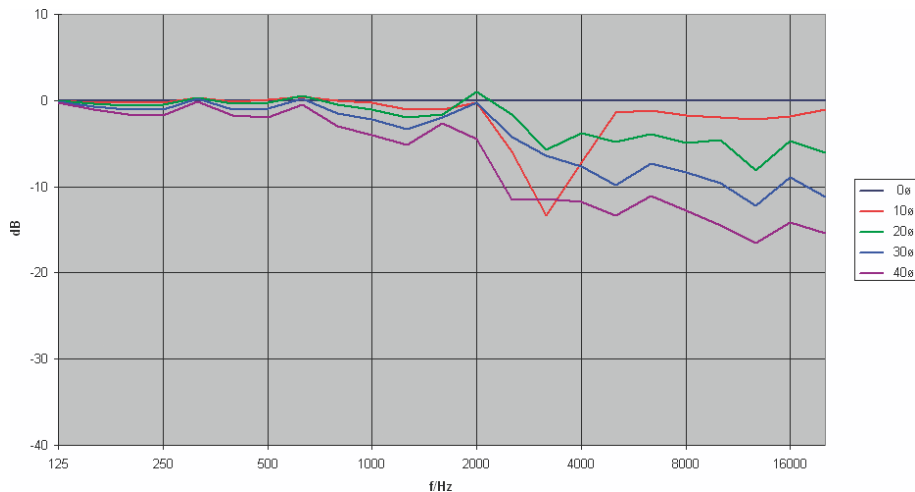

Century Point, Halifax Road, Cressex Business Park,
High Wycombe, Buckinghamshire HP12 3SL, England.
Telephone: +44 (0)1494 535312 Facsimile: +44 (0)1494 438669
E-mail: info@martin-audio.com
All information is Copyright © 2011 Martin Audio Ltd.



Beatline 10

Compact, full-range system

overall dimensions

Beatline

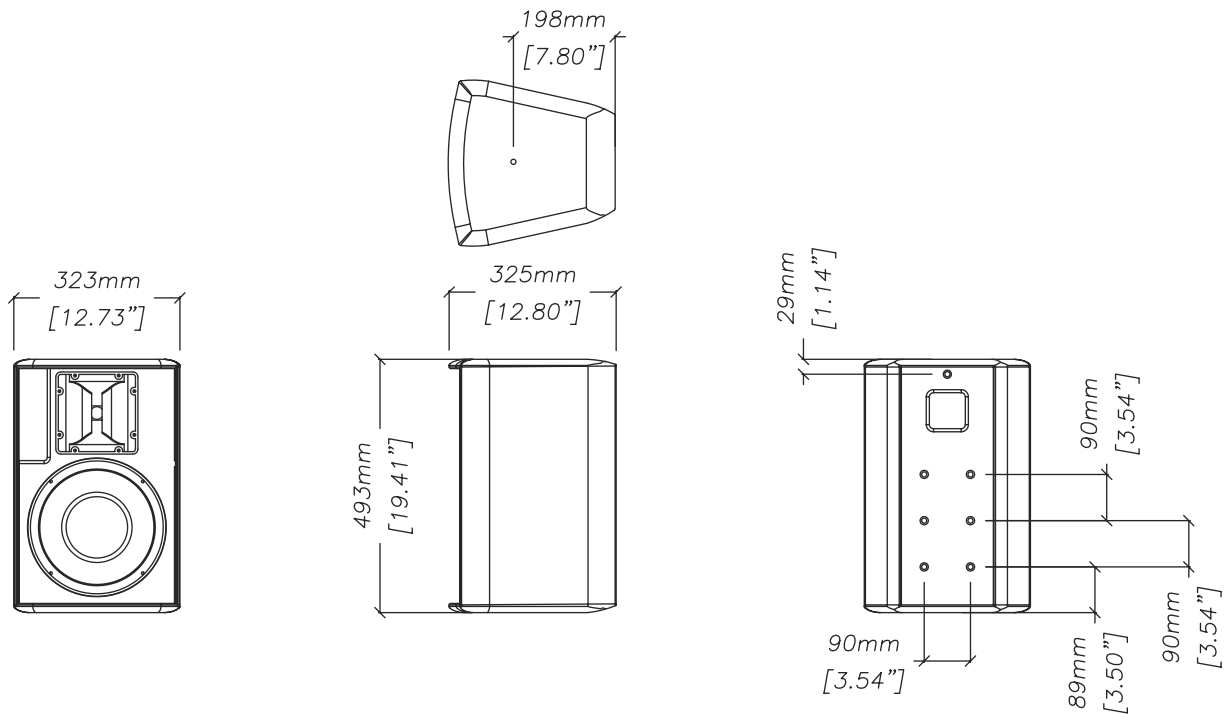

Beatline 10

Century Point, Halifax Road, Cressex Business Park,
High Wycombe, Buckinghamshire HP12 3SL, England.
Telephone: +44 (0)1494 535312 Facsimile: +44 (0)1494 438669
E-mail: info@martin-audio.com
All information is Copyright © 2011 Martin Audio Ltd.



Beatline 10

Compact, full-range system

technical specifications

TYPE	Compact, two-way passive, vented trapezoid
FREQUENCY RESPONSE (1)	65Hz-20kHz \pm 3dB
DRIVERS	10" (250mm) bass driver 1" (25mm) exit HF compression driver
RATED POWER (2)	300W AES, 1200W peak
RECOMMENDED AMPLIFIER	MA2.0
SENSITIVITY (6)	96dB
MAXIMUM SPL (7)	119dB continuous, 125dB peak
NOMINAL IMPEDANCE	8 ohms
DISPERSION (-6dB)	90° horizontal, 50° vertical
CROSSOVER	2.7kHz passive
ENCLOSURE	27 litre, braced 18mm MDF
FINISH	Textured black paint
PROTECTIVE GRILLE	Black perforated steel
CONNECTORS	Low profile 20 amp push-lock
FITTINGS	6 x M8 inserts for bracket 2 x M8 inserts for safety point
OPTIONS	150W 100/70V line transformer
DIMENSIONS	(W) 323mm x (H) 493mm x (D) 325mm (W) 12.7ins x (H) 19.4ins x (D) 12.8ins
WEIGHT	17kg (37lbs)

accessories

AQWB8	Wall Bracket
AQCS	Short Ceiling Bracket
AQCL	Long Ceiling Bracket
AQFB	Flying Bracket

Notes

- (1) Measured on-axis in half space at 2 metres, then referred to 1 metre.
- (2) AES Standard ANSI S4.26-1984.
- (3) Measured in half space at 2 metres with 1 watt input, using band limited pink noise, then referred to 1 metre.
- (4) Measured in half space at 2 metres using band limited pink noise, then referred to 1 metre.
- (5) Measured on-axis in open (4TT) space at 2 metres, then referred to 1 metre.
- (6) Measured in open (4TT) space at 2 metres with 1 watt input, using band limited pink noise, then referred to 1 metre.
- (7) Measured in open (4TT) space at 2 metres using band limited pink noise, then referred to 1 metre.

Trade Descriptions Act

Due to Martin Audio's policy of continuing improvement, we reserve the right to alter these specifications without prior notice. Martin Audio is committed to refining state of the art sound reinforcement, combining in-depth product and field applications research with advanced manufacturing techniques. Every Martin Audio product is built to the highest manufacturing standards and rigorously tested to ensure that it meets the performance criteria specified in the design.

architectural and engineering specifications

The loudspeaker system shall be of the two-way passive type consisting of one 10" (250mm) direct radiating reflex loaded low frequency transducer and one 1" (25mm) exit HF compression driver mounted on a user rotatable constant directivity horn in a trapezoidal MDF enclosure. The enclosure shall be fitted with threaded inserts for attachment to a custom bracket. An internal 2.7kHz passive crossover network shall integrate the low and high frequency sections.

Performance of the loudspeaker system with its electronic controller shall meet or exceed the following criteria:

Frequency response measured 1 metre on axis shall be 65Hz-20kHz \pm 3dB.

High frequency dispersion at -6dB points shall be 90°H x 50°V.

Power handling shall be 300W AES, 1200W peak.

Rated impedance shall be 8 ohms.

Maximum SPL measured at 1 metre on axis shall be 119dB continuous, 125dB peak.

Dimensions (W) 323mm x (H) 493mm x (D) 325mm (12.7ins x 19.4ins x 12.8ins).

Weight 17kg (37lbs).

The loudspeaker system shall be the Martin Audio Beatline 10.