

# CSX118-WR

Compact Subwoofer - Weatherised



## Features

- Compact, direct-radiator subwoofer
- 1 x 18" (460mm) driver with 4" (100mm) voice coil
- Water resistant cone
- Large ports for reduced air noise
- Zinc plated mild steel grille with powder coated finish
- Plywood cabinets with polyurea coating
- Operating temperature -20°C to +70°C
- Environmentally tested to meet IP24
- Flying points with fixings made from stainless steel
- Black or white standard colour options

## Applications

- Outdoor restaurants, bars, hotel areas
- Nearfield systems in outdoor stadia, transport hubs, concourses and theme parks



The CSX118-WR is a compact, high performance subwoofer that extends the low frequency operating range of the combined system to 35Hz and provides exceptional low frequency impact. An ideal partner for the CDD10-WR, CDD12-WR and CDD15-WR, it is suitable for outdoor applications where it will be subject to changing environmental conditions but sheltered from direct exposure to the elements. It features a long-excursion 18" (460mm)/4" (100 mm) voice coil driver with a water-resistant cone and triple roll surround in a compact reflex enclosure.

The design of the 18" driver maximises output while minimising power compression and distortion, and the four reflex ports have a large frontal area to reduce turbulent air noise at very high levels. The enclosure is constructed from plywood with polyurea

coating, while the driver is protected by water and particle resistant zinc plated mild steel grille with powder coated finish, which is pre-curved to withstand physical damage.

Finished in black (RAL9005) or white (RAL9016) as standard, CSX118-WR is supplied with flying points with fixings made from stainless steel. Operating temperature is from -20°C to +70°C and they are environmentally tested to meet IP24.

When used with CDD full-range systems, crossover and EQ functions can either be performed by the DX0.5 and DX4.0 system controllers, or by an iKON amplifier.

# CSX118-WR

## Compact Subwoofer - Weatherised



### Technical Specifications

#### Acoustical

TYPE	Compact, direct radiating subwoofer
FREQUENCY RESPONSE (1)	40Hz-150Hz $\pm$ 3dB -10dB @ 35Hz
DRIVER	18" (460mm)/4" (100mm) voice coil, long excursion, ferrite magnet, waterproof cone
RATED POWER (2)	1000W AES, 4000W peak
RECOMMENDED AMPLIFIER	iK42 / VIA5002/5004
SENSITIVITY (10)	102dB
MAXIMUM SPL (9)	132dB continuous, 138dB peak (half space)
NOMINAL IMPEDANCE	8 ohms
DISPERSION (-6dB)	Omnidirectional
CROSSOVER	80-120Hz active
ENCLOSURE	160 litre, Exterior grade Plywood, Flying points with fixings made from stainless steel
FINISH	Black or white Poly Urea coating
PROTECTIVE GRILLE	Black or white zinc plated mild steel grille with powder coated finish
ENVIROMENTAL	Rated at IP24
CONNECTORS	Low profile 20A push-lock, weatherproof input panel cover with cable gland
PIN CONNECTIONS	Left to right: Input+, Input -, Link -, Link+
DIMENSIONS	(W) 662mm x (H) 530mm x (D) 640mm (W) 26.1ins x (H) 20.9ins x (D) 25.2ins
WEIGHT	43kg (94.8lbs)

#### Notes

- (1) Measured on-axis in half (2pi) space at 2 metres, then referred to 1 metre.
- (2) AES Standard ANSI S4.26-1984.
- (3) Measured in half (2pi) space at 2 metres with 1 watt input, using band limited pink noise, then referred to 1 metre.
- (4) Measured in half (2pi) space at 2 metres using band limited pink noise, then referred to 1 metre.
- (5) Measured on-axis in open (4pi) space at 2 metres, then referred to 1 metre.
- (6) Measured in open (4pi) space at 2 metres with 1 watt input, using band limited pink noise, then referred to 1 metre.
- (7) Measured in open (4pi) space at 2 metres using band limited pink noise, then referred to 1 metre.
- (8) Measured in open (4pi) space at 2 metres with 2.83V input, using band limited pink noise, then referred to 1 metre.
- (9) Calculated at 1 metre.
- (10) Measured in half (2pi) space at 2 metres with 2.83V input, using band limited pink noise, then referred to 1 metre.

#### Trade Descriptions Act

Due to Martin Audio's policy of continuing improvement, we reserve the right to alter these specifications without prior notice. Martin Audio is committed to refining state of the art sound reinforcement, combining in-depth product and field applications research with advanced manufacturing techniques. Every Martin Audio product is built to the highest manufacturing standards and rigorously tested to ensure that it meets the performance criteria specified in the design.

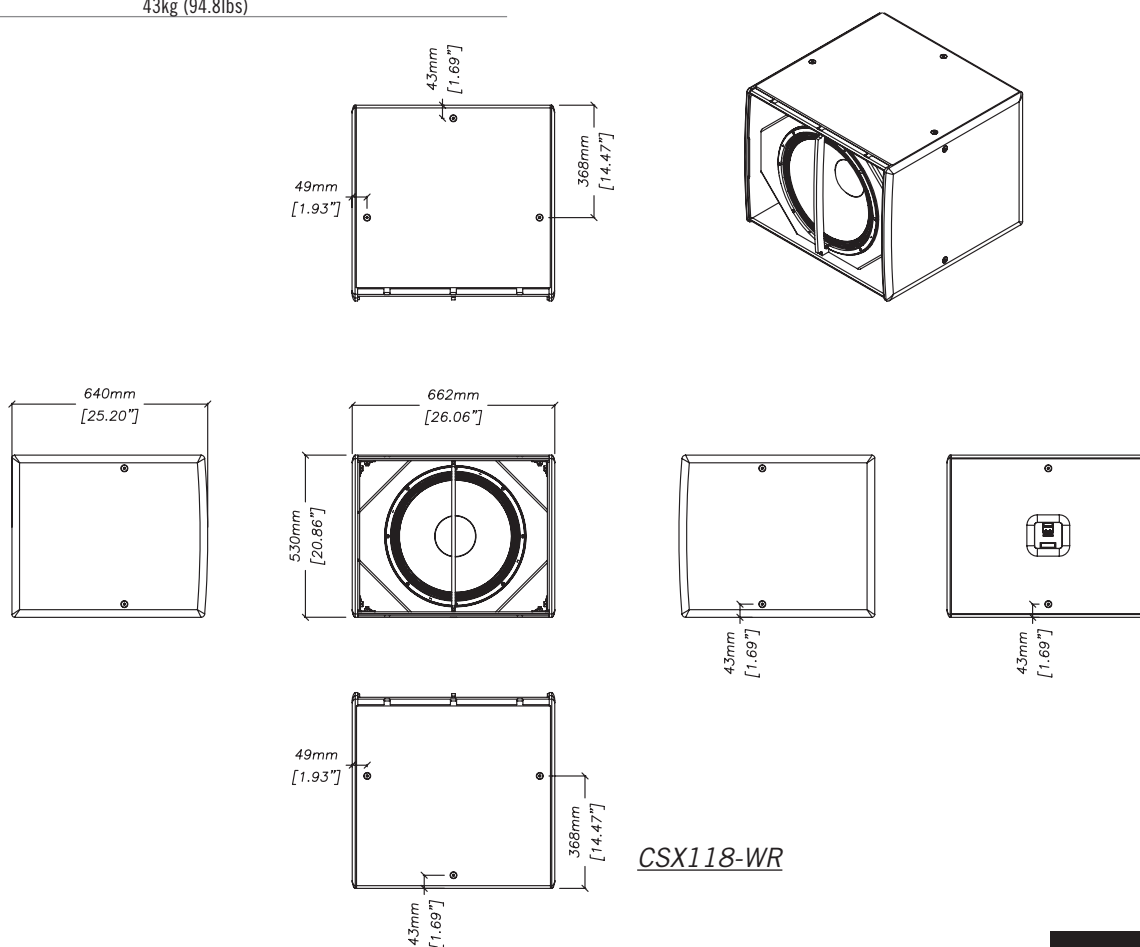

CSX118-WR