

Effect 3R

Two-way passive surround system

cinema

features

- ▶ Two-way passive design
- ▶ THX™ approved
- ▶ Reduced height for low ceiling cinemas

applications

- ▶ Powerful surround sound applications
- ▶ For medium cinemas



The Effect 3R is a two-way passive cinema surround system, designed to produce smooth, full-range surround sound. It may be installed in medium sized cinemas, screening rooms and under-balcony applications.

This reduced height enclosure is ideally suited for installation in rooms with a low ceiling.

The system features an 8" (200mm) bass driver and a 1" (25mm) HF device mounted on a 90° x 90° circular waveguide which accurately controls the directivity of the system above 2kHz. The crossover network has been designed to allow easy selection between flat response and the SMPTE/ISO 2969 X-curve.

The shape of the Effect 3R allows it to be wall mounted with a 15° downward angle by means of its simple fixing bracket. The black textured finish and slimline construction mean the enclosure blends unobtrusively in cinema auditoria.

Century Point, Halifax Road, Cressex Business Park,
High Wycombe, Buckinghamshire HP12 3SL, England.
Telephone: +44 (0)1494 535312 Facsimile: +44 (0)1494 438669
E-mail: info@martin-audio.com
All information is Copyright © 2003 Martin Audio Ltd.



Effect 3R

Two-way passive surround system

overall dimensions

cinema

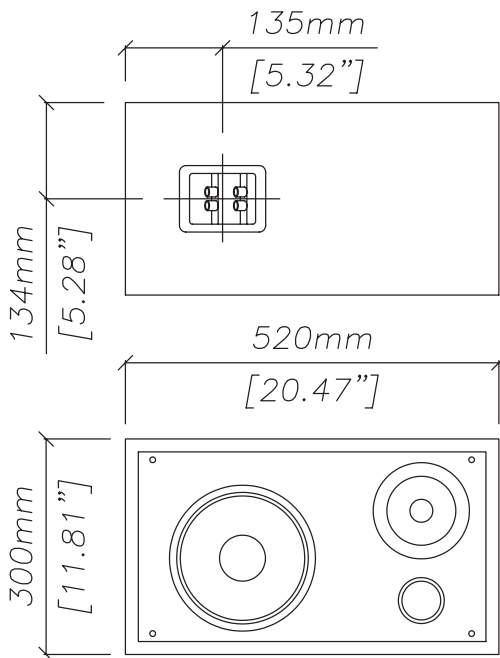

**NOTE:
SHOWN WITHOUT FRONT GRILLE,
DIMENSION WITH GRILLE IS 284mm(11.18")*

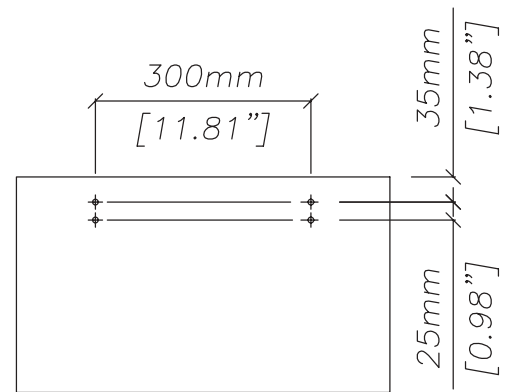
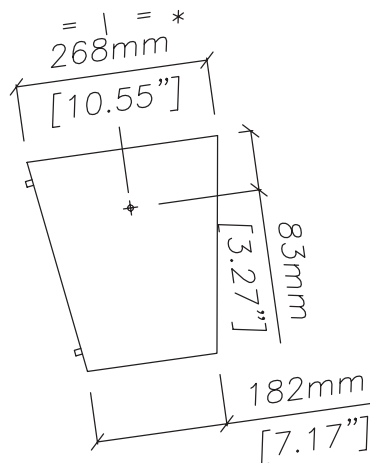

EFFECT 3R

Century Point, Halifax Road, Cressex Business Park,
High Wycombe, Buckinghamshire HP12 3SL, England.
Telephone: +44 (0)1494 535312 Facsimile: +44 (0)1494 438669
E-mail: info@martin-audio.com
All information is Copyright © 2003 Martin Audio Ltd.



Effect 3R

Two-way passive surround system

technical specifications

TYPE	Two-way passive, reflex enclosure
FREQUENCY RESPONSE (1)	80Hz-20kHz \pm 3dB
LOW FREQUENCY LIMIT	-10dB @ 50Hz
DRIVERS	8" (200mm) bass-mid driver 1" (25mm) dome tweeter on waveguide
RATED POWER (2)	100W AES, 400W peak
RECOMMENDED AMPLIFIER	MA2.0/ MA4.8Q
SENSITIVITY (3)	91dB 1 Watt/1 metre
MAXIMUM SPL (4)	109dB continuous, 115dB peak
IMPEDANCE	8 ohms nominal (flat response) 6 ohms nominal (SMPTE/ISO 2969 X-curve)
DISPERSION (-6dB)	90° horizontal, 90° vertical
CROSSOVER	2.5kHz passive Externally selectable flat or SMPTE/ISO 2969 X-curve
ENCLOSURE	24 litre (0.75cu foot) particle board construction
FINISH	Black texture
PROTECTIVE GRILLE	Black acoustically transparent cloth grille
CONNECTORS	2-way binding posts
FITTINGS	4 x M4 teenuts on rear for 'keyhole' brackets 2 x keyhole plates 2 x M8 threaded inserts for wall bracket 1 x wall bracket (optional)
DIMENSIONS	(W) 520mm x (H) 300mm x (D) 284mm (W) 20.5ins x (H) 11.8ins x (D) 11.2ins
WEIGHT	13.0kg (27lbs)

accessories

HTK-EFFECT 5B Adjustable Bracket



approved by Lucasfilm for use in THX™ theatres.

Notes

- (1) Measured on-axis in half space at 2 metres, then referred to 1 metre.
- (2) AES Standard ANSI S4.26-1984.
- (3) Measured in half space conditions at 2 metres with 1 watt input, using band limited pink noise, then referred to 1 metre.
- (4) Measured in half space conditions at 2 metres using band limited pink noise, then referred to 1 metre.

Trade Descriptions Act

Due to Martin Audio's policy of continuing improvement, we reserve the right to alter these specifications without prior notice. Martin Audio is committed to refining state of the art sound reinforcement, combining in-depth product and field applications research with advanced manufacturing techniques. Every Martin Audio product is built to the highest manufacturing standards and rigorously tested to ensure that it meets the performance criteria specified in the design.

architectural and engineering specifications

The loudspeaker system shall be of the two-way passive type consisting of one 8" (200mm) direct radiating reflex loaded low/mid frequency transducer and one 1" (25mm) HF device mounted on a 90° x 90° circular waveguide in a slimline enclosure. The enclosure shall be fitted with threaded inserts for mounting brackets. Low and high frequency sections shall be integrated by an internal 2.5kHz passive crossover network, which is fitted with an external switch to facilitate easy selection between a flat or SMPTE/ISO 2969 X-curve.

Performance of the loudspeaker system shall meet or exceed the following criteria:

Frequency response measured 1 metre on axis shall be 80Hz-20kHz \pm 3dB.

High frequency dispersion at -6dB points shall be 90° H x 90° V.

Power handling shall be 100W AES, 400W peak.

Rated impedance shall be 8 ohms.

Maximum SPL measured at 1 metre on axis shall be 109dB continuous, 115dB peak.

Dimensions (W) 520mm x (H) 300mm x (D) 284mm (20.5ins x 11.8ins x 11.2ins).

Weight 13kg (27lbs).

The loudspeaker system shall be approved by Lucasfilm for use in THX™ Theatres.

The loudspeaker system shall be the Martin Audio Effect 3R.

Century Point, Halifax Road, Cressex Business Park,
High Wycombe, Buckinghamshire HP12 3SL, England.
Telephone: +44 (0)1494 535312 Facsimile: +44 (0)1494 438669
E-mail: info@martin-audio.com
All information is Copyright © 2003 Martin Audio Ltd.

