

Blackline H3H

All-horn three-way system

features

- ▶ All-horn three-way system
- ▶ 'Phase-ball' loaded mid-driver
- ▶ Hybrid™ LF section
- ▶ Fitted with handles and castors
- ▶ Horizontal format for low profile installs
- ▶ Five year limited warranty

applications

- ▶ Larger club performance
- ▶ Large scale installs

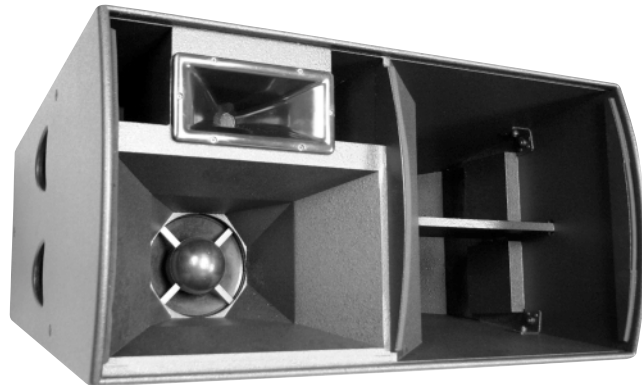

The Blackline H3H is a very high performance, all-horn, three-way system in a single, horizontally formatted, wide-bandwidth package. The Hybrid™ low frequency section comprises a horn-loaded 15" (380mm) / 4" (100mm) voice coil driver that is reflex loaded to extend the LF output to below the natural horn cut-off point. The 10" (250mm) mid-horn features a unique 'phase-ball' loading device and is teamed with a 70° x 40° horn-loaded 1" (25mm) exit compression driver for efficient mid-HF performance. The system has a passive 2kHz mid-HF crossover network to permit bi-amp operation using the M3 Electronic Controller.

The H3H is housed in a horizontal format, trapezoidal birch ply cabinet and fitted with twelve M10 inserts to facilitate ease of mounting. Generous handles and rear castors are fitted for easy cabinet deployment.

A Martin Audio M3 Electronic Controller is available to provide H3H crossover and limiter facilities. See M3 Electronic Controller Technical Specifications for suitable M3 Controller Cards.

Century Point, Halifax Road, Cressex Business Park,
High Wycombe, Buckinghamshire HP12 3SL, England.
Telephone: +44 (0)1494 535312 Facsimile: +44 (0)1494 438669
E-mail: info@martin-audio.com
All information is Copyright © 2003 Martin Audio Ltd.



professional

Blackline H3H

All-horn three-way system

polar plots

professional

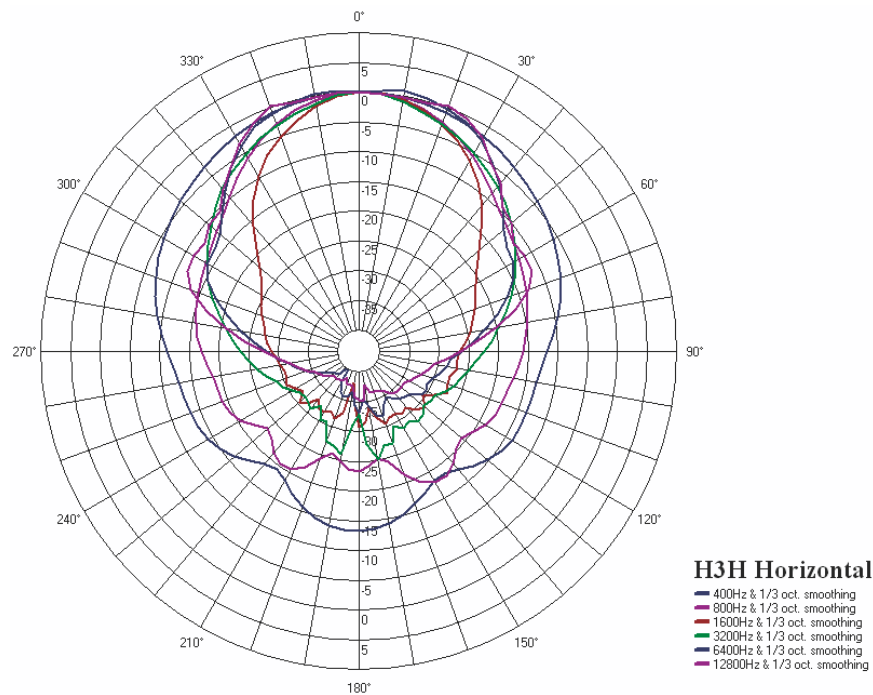
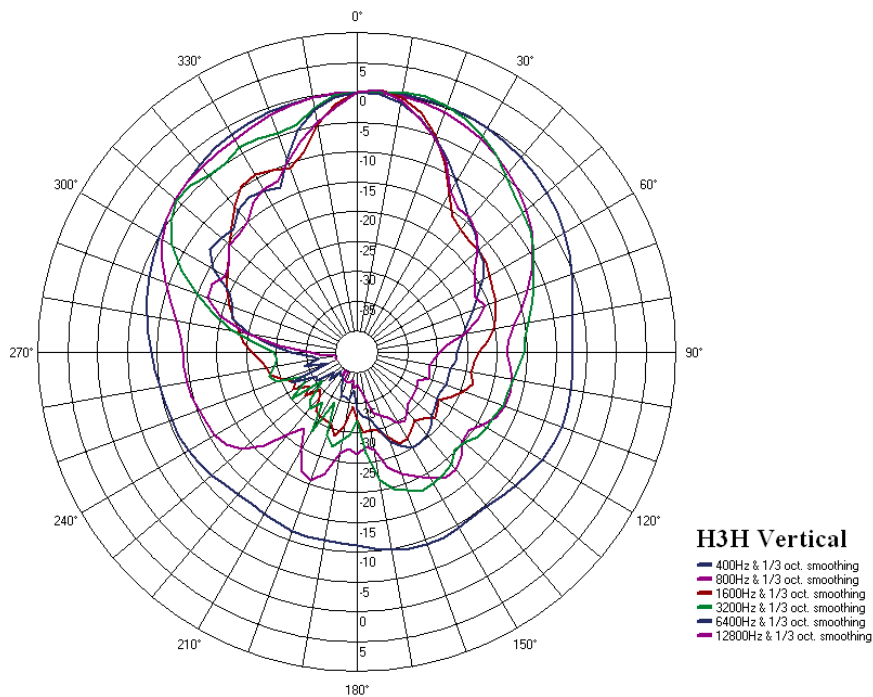

Century Point, Halifax Road, Cressex Business Park,
High Wycombe, Buckinghamshire HP12 3SL, England.
Telephone: +44 (0)1494 535312 Facsimile: +44 (0)1494 438669
E-mail: info@martin-audio.com
All information is Copyright © 2003 Martin Audio Ltd.



Blackline H3H

All-horn three-way system

frequency responses

professional

H3H Horizontal Magnitude in dB SPL at meter

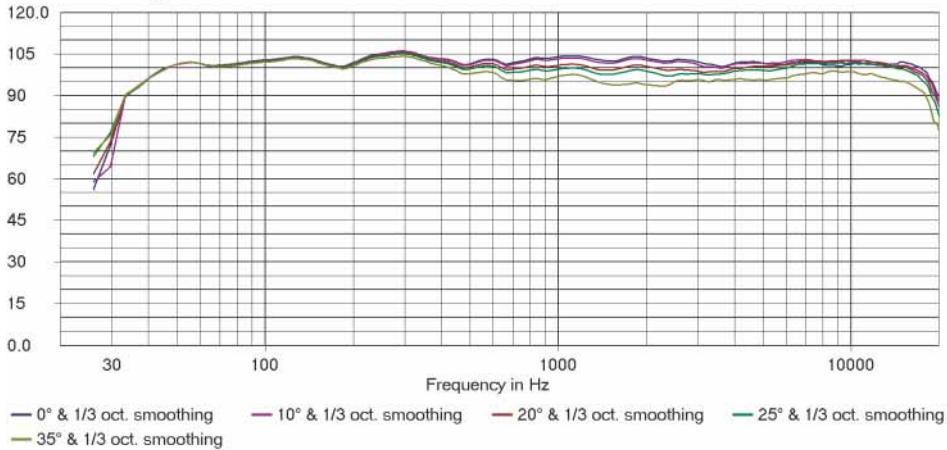

H3H Horizontal Beamwidth

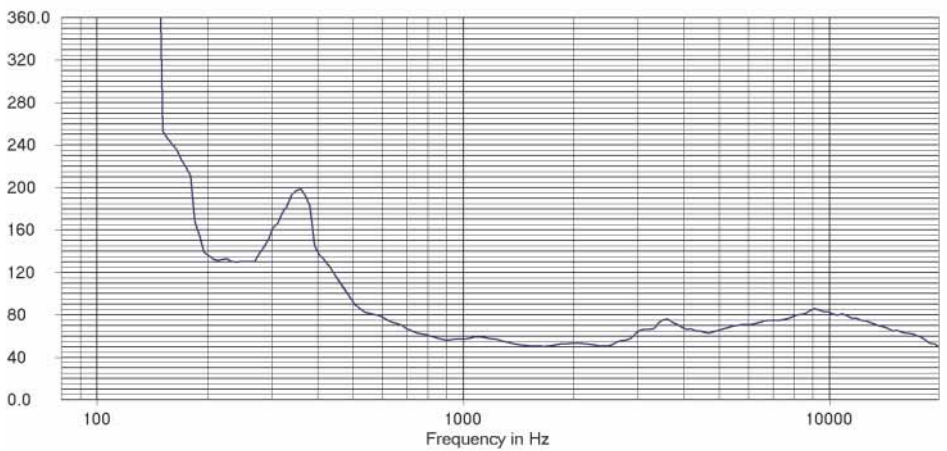

H3H Vertical Beamwidth

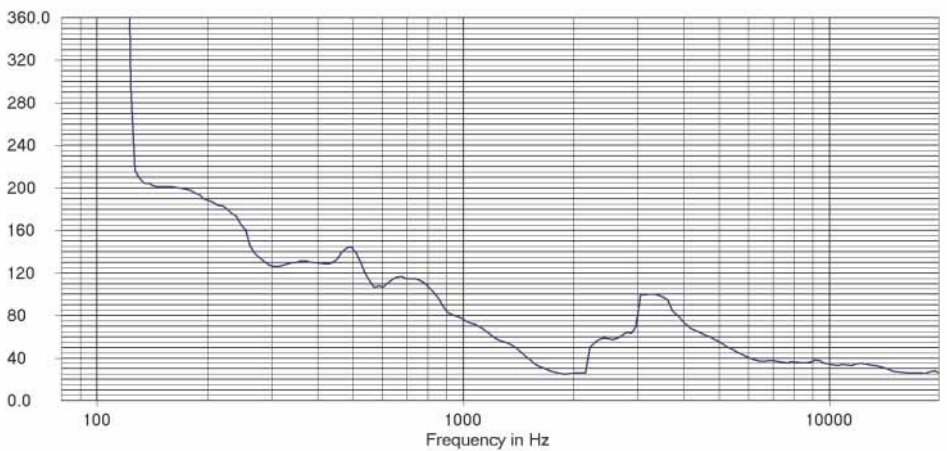

Century Point, Halifax Road, Cressex Business Park,
High Wycombe, Buckinghamshire HP12 3SL, England.
Telephone: +44 (0)1494 535312 Facsimile: +44 (0)1494 438669
E-mail: info@martin-audio.com
All information is Copyright © 2003 Martin Audio Ltd.



Blackline H3H

All-horn three-way system

overall dimensions

professional

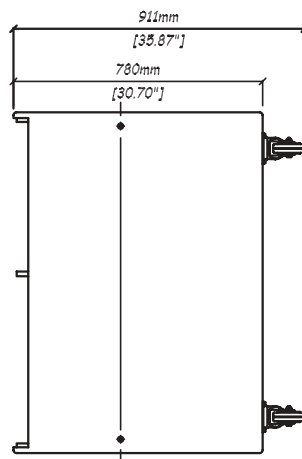
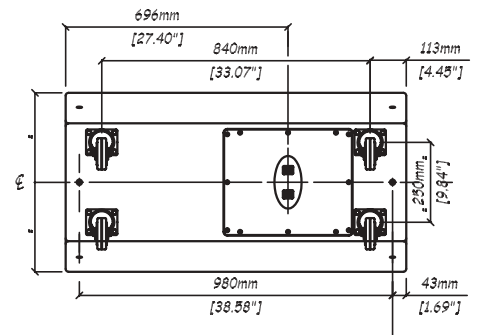
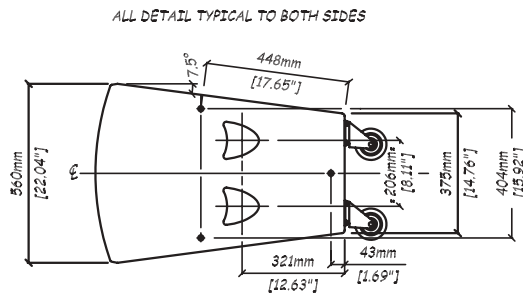
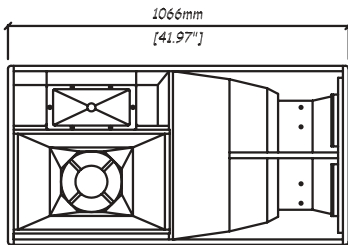

H3H

Century Point, Halifax Road, Cressex Business Park,
High Wycombe, Buckinghamshire HP12 3SL, England.
Telephone: +44 (0)1494 535312 Facsimile: +44 (0)1494 438669
E-mail: info@martin-audio.com
All information is Copyright © 2003 Martin Audio Ltd.



Blackline H3H

All-horn three-way system

professional

technical specifications

TYPE	Three-way bi-amp trapezoid Hybrid™ fully horn-loaded
FREQUENCY RESPONSE (1)	50Hz-18kHz ± 3dB
DRIVERS	15" (380mm) bass driver 10" (250mm) mid driver 1" (25mm) exit compression driver
RATED POWER (2)	LF: 500W AES, 2000W peak MF + HF: 300W AES, 1200W peak
RECOMMENDED AMPLIFIER	LF: 400-1000W into 4 ohms MF + HF: 400-650W into 4 ohms
SENSITIVITY (6)	LF: 104dB, MF + HF: 104dB
MAXIMUM SPL (7)	130dB continuous, 136dB peak
NOMINAL IMPEDANCE	LF: 8 ohms, MF + HF: 8 ohms
DISPERSION (-6dB)	70° horizontal, 40° vertical
CROSSOVER	200Hz active, 2kHz passive
ENCLOSURE	250 litre, multi-laminate birch ply
FINISH	Textured black paint
PROTECTIVE GRILLE	Black perforated steel
CONNECTORS	2 x Neutrik NL4
FITTINGS	12 x M10 inserts 4 x 4" (100mm) castors
OPTIONS	150W 100/70V line transformer
DIMENSIONS	(W) 1066mm x (H) 560mm x (D) 780mm (911mm) (W) 42ins x (H) 22ins x (D) 30.7ins (35.9ins)
WEIGHT	77.5kg (170.5lbs)

accessories

HTKCT06 10mm Shouldered Eye Bolt

Notes

- (1) Measured on-axis in half space at 2 metres, then referred to 1 metre.
- (2) AES Standard ANSI S4.26-1984.
- (3) Measured in half space conditions at 2 metres with 1 watt input, using band limited pink noise, then referred to 1 metre.
- (4) Measured in half space conditions at 2 metres using band limited pink noise, then referred to 1 metre.

Trade Descriptions Act

Due to Martin Audio's policy of continuing improvement, we reserve the right to alter these specifications without prior notice. Martin Audio is committed to refining state of the art sound reinforcement, combining in-depth product and field applications research with advanced manufacturing techniques. Every Martin Audio product is built to the highest manufacturing standards and rigorously tested to ensure that it meets the performance criteria specified in the design.

architectural and engineering specifications

The loudspeaker system shall be of the trapezoidal three-way bi-amp Hybrid™ fully horn-loaded type, horizontally formatted and consisting of one 15" (380mm) horn and reflex loaded low frequency transducer, one 10" (250mm) horn loaded mid frequency transducer with a "phase-ball" loading device and one 1" (25mm) exit HF compression driver mounted on a constant directivity horn. The enclosure shall be of a multi-laminate birch ply construction with threaded inserts to simplify mounting and fitted with 4" castors for easy deployment. The loudspeaker shall be operated with a separate electronic controller providing a 250Hz crossover between low and mid/high frequency sections. The mid and high frequency sections shall be integrated by an internal 2kHz passive crossover network.

Performance of the loudspeaker system with its electronic controller shall meet or exceed the following criteria:

Frequency response measured 1 metre on axis shall be 50Hz-18kHz ± 3dB.

High frequency dispersion at -6dB points shall be 70° H x 40° V.

Power handling shall be 500W AES, 2000W peak LF, 300W AES, 1200W peak MF + HF.

Rated impedance shall be 8 ohms LF, 8 ohms MF + HF. Maximum SPL measured at 1 metre on axis shall be 130dB continuous, 136dB peak.

Dimensions (W) 1066mm x (H) 560mm x (D) 780mm (42ins x 22ins x 30.7ins).

Weight 77.5kg (170.5lbs).

The loudspeaker system shall be the Martin Audio H3H.

Century Point, Halifax Road, Cressex Business Park,
High Wycombe, Buckinghamshire HP12 3SL, England.
Telephone: +44 (0)1494 535312 Facsimile: +44 (0)1494 438669
E-mail: info@martin-audio.com
All information is Copyright © 2003 Martin Audio Ltd.

