

W8C

Compact three-way mid-high system

features

- ▶ Very high SPL capability
- ▶ Compact arrayable trapezoid cabinet
- ▶ Three-way horn loaded system
- ▶ Constant 55° dispersion
- ▶ Switchable active/passive HF
- ▶ Load certified MAN flying points

applications

- ▶ Live sound – concert halls, theatres, open-air venues
- ▶ Fixed installations – multi-purpose auditoria, theatres, sports arenas



touring and theatre

The award-winning Wavefront W8C is lightweight and compact. It can be rigged quickly to deliver outstanding power and performance in smaller configurations than was previously possible with other loudspeakers. Audience experience is enhanced by true musicality, warmth and intelligibility - even at high SPL's.

Ground-breaking three-way technology marries a low-mid horn-loaded 12" (300mm) cone drive unit with a unique combination of 6.5" (165mm) high-mid driver loaded by toroidal phase plug and horn plus a 1" (25mm) exit HF device, optimised for very high frequencies. The result - a remarkably clean, transparent sound, far lower distortion and increased overall output, without pushing any element to the limit.

The W8C confirms the trend for increasingly compact systems. A typical arena system flown 6 cabinets wide and 3-4 deep is both lightweight and pleasing to the eye of the production manager. Using the MAN flying system has the safety advantage that inter-cabinet connections place no load on the cabinets and, being external, can be load certified and inspected independently.

Century Point, Halifax Road, Cressex Business Park,
High Wycombe, Buckinghamshire HP12 3SL, England.
Telephone: +44 (0)1494 535312 Facsimile: +44 (0)1494 438669
E-mail: info@martin-audio.com
All information is Copyright © 2011 Martin Audio Ltd.



W8C

Compact three-way mid-high system

polar plots

touring and theatre

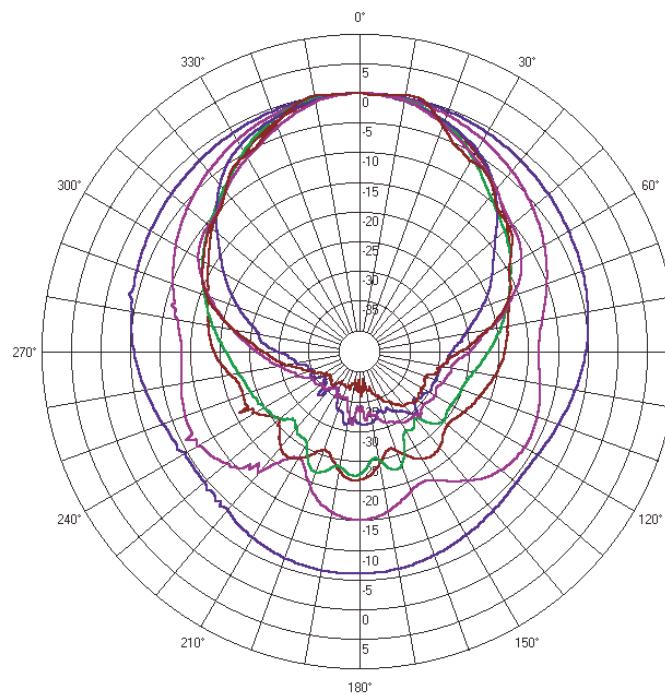
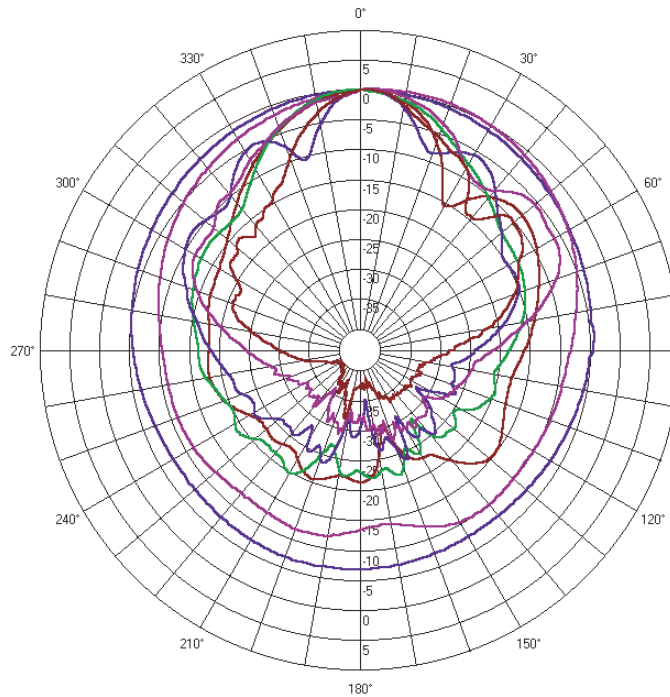

Century Point, Halifax Road, Cressex Business Park,
High Wycombe, Buckinghamshire HP12 3SL, England.
Telephone: +44 (0)1494 535312 Facsimile: +44 (0)1494 438669
E-mail: info@martin-audio.com
All information is Copyright © 2011 Martin Audio Ltd.



W8C

Compact three-way mid-high system

frequency responses

W8C Horizontal Magnitude in dB SPL/2.83V at 1 meter

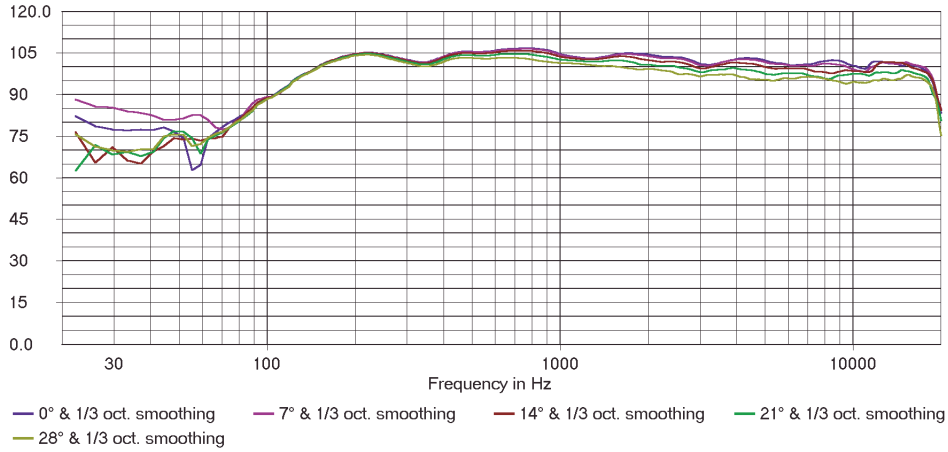

W8C Horizontal Beamwidth

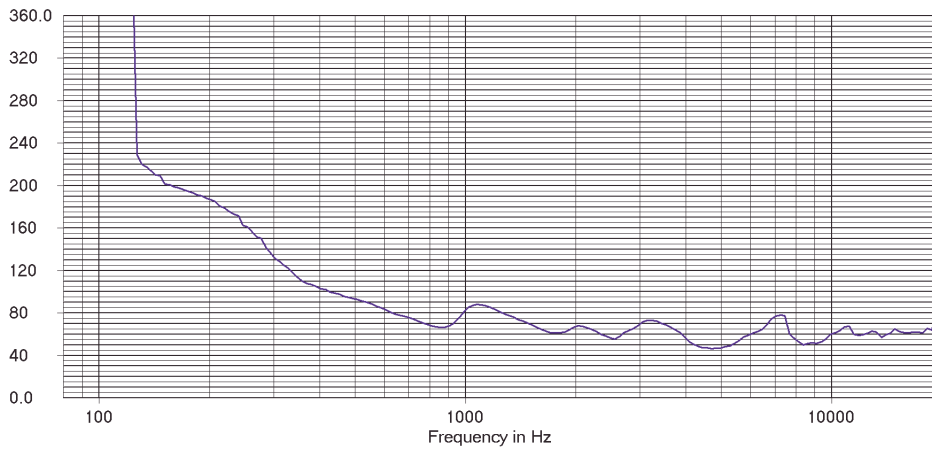

W8C Vertical Beamwidth

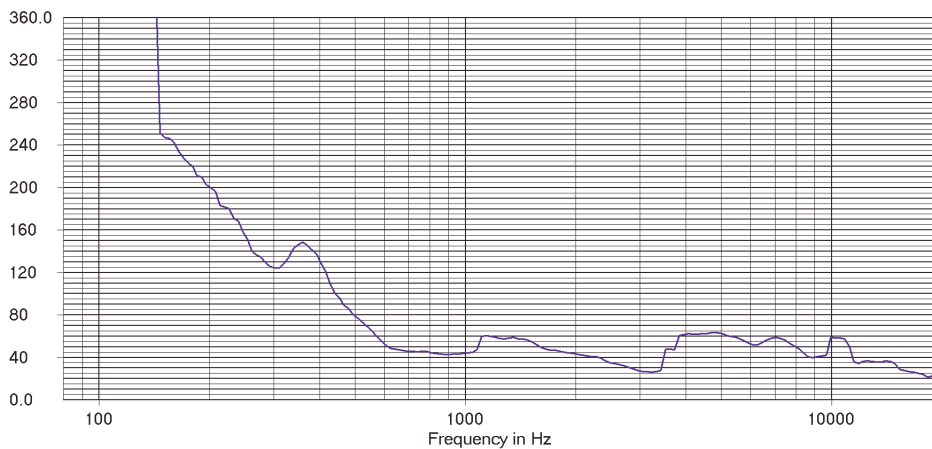

Century Point, Halifax Road, Cressex Business Park,
High Wycombe, Buckinghamshire HP12 3SL, England.
Telephone: +44 (0)1494 535312 Facsimile: +44 (0)1494 438669
E-mail: info@martin-audio.com
All information is Copyright © 2011 Martin Audio Ltd.



touring and theatre

W8C

Compact three-way mid-high system

overall dimensions

touring and theatre

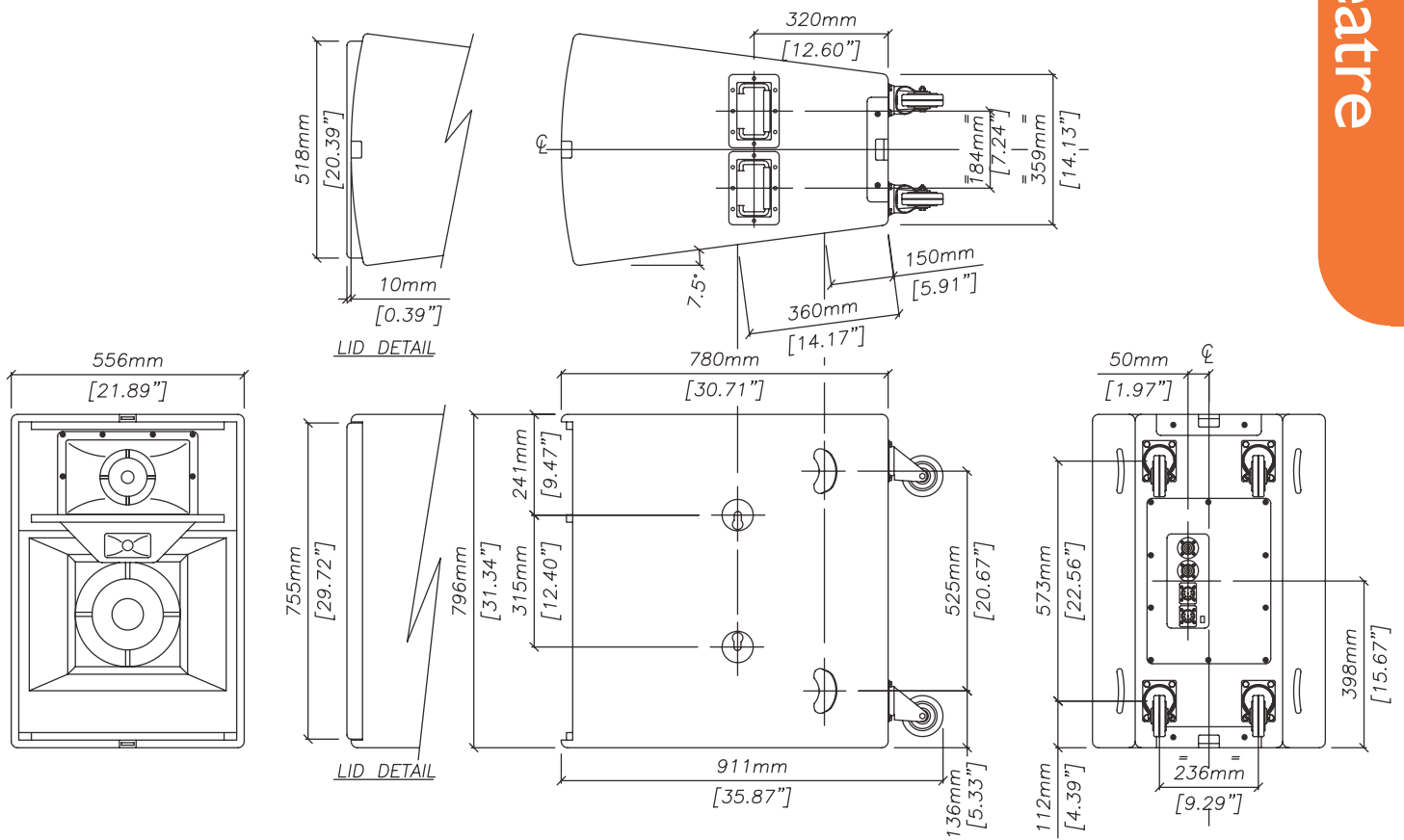

W8C

Century Point, Halifax Road, Cressex Business Park,
High Wycombe, Buckinghamshire HP12 3SL, England.
Telephone: +44 (0)1494 535312 Facsimile: +44 (0)1494 438669
E-mail: info@martin-audio.com
All information is Copyright © 2011 Martin Audio Ltd.



W8C

Compact three-way mid-high system

technical specifications

TYPE	Three-way full-range trapezoid, switchable active/passive HF
FREQUENCY RESPONSE (5)	120Hz-18kHz \pm 3dB -10dB @ 100Hz
DRIVERS	12" (300mm) low-mid horn 6.5" (165mm) high-mid horn 1" (25mm) exit HF compression driver
RATED POWER (2)	Low-mid: 300W AES, 1200W peak High-mid/(High-mid + HF): 150W AES, 600W peak HF: 60W AES, 240W peak
RECOMMENDED AMPLIFIER	MA3.0 / MA2.0
SENSITIVITY (6)	Low-mid: 106dB High-mid/(High-mid + HF): 108dB HF: 107dB
MAXIMUM SPL (calculated @ 1m)	130dB continuous, 136dB peak
NOMINAL IMPEDANCE	LF: 8 ohms High-mid/(High-mid + HF): 16 ohms HF: 16 ohms
DISPERSION (-6dB)	55° horizontal, 30° vertical
CROSSOVER	750Hz active, 3.5kHz active/passive
FINISH	Textured grey paint
PROTECTIVE GRILLE	Grey perforated steel
CONNECTORS	2 x Neutrik NL8, 2 x EP8
FITTINGS	4 x MAN Flying points
DIMENSIONS (inc. wheels)	(W) 556mm x (H) 799mm x (D) 780mm (911mm) (W) 21.9ins x (H) 31.5ins x (D) 30.7ins (35.9ins)
WEIGHT	71kg (156.5lbs)

accessories

HTKQF8	Quick release flying stud / D-ring
HTKHIS	Heavyweight install stud
HTKW8HingeKit	Complete hinge kit

Notes

- (1) Measured on-axis in half space at 2 metres, then referred to 1 metre.
- (2) AES Standard ANSI S4.26-1984.
- (3) Measured in half space at 2 metres with 1 watt input, using band limited pink noise, then referred to 1 metre.
- (4) Measured in half space at 2 metres using band limited pink noise, then referred to 1 metre.
- (5) Measured on-axis in open (4π) space at 2 metres, then referred to 1 metre.
- (6) Measured in open (4π) space at 2 metres with 1 watt input, using band limited pink noise, then referred to 1 metre.
- (7) Measured in open (4π) space at 2 metres using band limited pink noise, then referred to 1 metre.
- (8) Measured in open (4π) space at 2 metres with 2.83V input, using band limited pink noise, then referred to 1 metre.
- (9) Calculated at 1 metre.

Trade Descriptions Act

Due to Martin Audio's policy of continuing improvement, we reserve the right to alter these specifications without prior notice. Martin Audio is committed to refining state of the art sound reinforcement, combining in-depth product and field applications research with advanced manufacturing techniques. Every Martin Audio product is built to the highest manufacturing standards and rigorously tested to ensure that it meets the performance criteria specified in the design.

architectural and engineering specifications

The loudspeaker system shall be of the three-way type with switchable active/passive HF. The low-mid section shall consist of one 12" (300mm) cone transducer mounted on a horn flare with a precision moulded waveguide. The high-mid section shall consist of a 6.5" (165mm) cone driver mounted on a constant directivity horn flare with integral toroidal waveguide. The high frequency section shall consist of a 1" (25mm) exit HF compression driver mounted on a constant directivity horn which shall be internally protected for signals below its intended passband by a power and frequency matching network. The enclosure shall be of the heavily braced multi-laminate trapezoidal plywood type.

Performance of the loudspeaker system with its electronic controller shall meet or exceed the following criteria:

Frequency response measured 1 metre on axis shall be 120Hz-18kHz \pm 3dB.

High frequency dispersion at -6dB points shall be 55° H x 30° V.

Power handling shall be 300W AES, 1200W peak Low-mid, 150W AES, 600W peak High-mid/(HF), 60W AES, 240W peak HF.

Rated impedance shall be 8 ohms Low-mid, 16 ohms High-mid/(High-mid HF), 16 ohms HF.

Maximum SPL measured at 1 metre on axis shall be 130dB continuous, 136dB peak.

Dimensions (W) 556mm x (H) 799mm x (D) 911mm (21.9ins x 31.5ins x 35.9ins).

Weight 71kg (156.5lbs).

The loudspeaker system shall be the Martin Audio W8C.

Century Point, Halifax Road, Cressex Business Park,
High Wycombe, Buckinghamshire HP12 3SL, England.
Telephone: +44 (0)1494 535312 Facsimile: +44 (0)1494 438669
E-mail: info@martin-audio.com
All information is Copyright © 2011 Martin Audio Ltd.

