

Contents

Warning notices	3
1 Installation and operation.....	6
1.1 Unpacking	6
1.2 Mounting	6
1.3 Operating Precautions	7
1.4 AC Main connection	7
1.5 Connecting Inputs	8
1.6 Connecting Outputs	9
2 Setup and settings	10
2.1 Introduction	10
2.2 The LED indicators	11
3 Protection.....	12
3.2 Short circuit protection	12
3.3 Thermal protection	12
3.4 DC fault protection	12
4 User Maintenance.....	13
4.1 Cleaning	13
4.2 Service.....	13
4.3 Dust removal.....	13
5 Warranty.....	14
7 Technical notes	15
7.1 Block diagram.....	15
7.2 Thermal Dissipation	16
7.3 Specification	17
7.4 Technical Drawing.....	18

Important safety instructions



Caution

To reduce the risk of electric shock, do not remove the cover. No user-serviceable parts inside. Refer servicing to qualified service personnel.

Safeguards

Electrical energy can perform many useful functions. This unit has been engineered and manufactured to assure your personal safety. Improper use can result in potential electrical shock or fire hazards. In order not to defeat the safeguards, observe the following instructions for its installation, use and servicing.

Approvals



*

This equipment has been tested and found to comply by Competent Body (Directive 89/336/EEC-EMC) pursuant to the product family standard for audio professional use: EN 55103-1 and EN 55103-2 standard); EN61000-3-2, EN 61000-3-3.

In a domestic environment this product may cause radio interferences in which case the user may be required to take adequate measures.

NOTES: This equipment has been tested and found to comply by Competent Body (Directive 89/336/EEC-EMC) pursuant to the product family standard for audio professional use: EN 55103-1 and EN 55103-2 standard); EN61000-3-2 , EN 61000-3-3.

This is a class A product. In a domestic environment this product may cause radio interferences in which case the user may be required to take adequate measures.

This equipment has been tested and found to comply by Notified Body (Directive 2006/95/EEC L.V) pursuant to the audio apparatus safety requirements: Standard EN 60065.

NOTE:

This equipment has been tested and found to comply with the limits for a Class A digital device, pursuant to part 15 of the FCC Rules. These limits are designed to provide reasonable protection against harmful interference when the equipment is operated in a commercial environment. This equipment generates, uses, and can radiate radio frequency energy and, if not installed and used in accordance with the instruction manual, may cause harmful interference to radio communications. Operation of this equipment in a residential area is likely to cause harmful interference in which case the user will be required to correct the interference at his own expense.

Warning notices

Location



Install the amplifier in a well-ventilated location where it will not be exposed to high temperature or humidity.

Do not install the amplifier in a location that is exposed to direct rays of the sun, or near to hot appliances or radiators.

Excessive heat can adversely affect the cabinet and internal components.

Installation of the amplifier in a damp or dusty environment may result in malfunction or accident.



Precautions regarding installation

Placing and using the amplifier for long periods on heat-generation sources will affect performances.

Avoid placing the amplifier on heat-generating sources.

Install this amplifier as far as possible from tuners and TV sets. An amplifier installed in close proximity to such equipment may cause noise or degradation of the picture.

WARNING: To prevent fire or electric shock:

-  Do not expose this equipment to rain or moisture.
-  Apparatus shall not be exposed to dripping or splashing and no objects filled with liquids, such as vases, shall be placed on the apparatus".







Safety rules



This device must be powered exclusively by earth connected mains sockets in electrical networks compliant to the IEC 364 or similar rules.

It is absolutely necessary to verify this fundamental requirement of safety and, in case of doubt, requires an accurate check by qualified personnel.

The constructor cannot be considered responsible for eventual damages caused to persons, things or data for the missing of accurate earth link.

-  Before powering this device verify that the amplifier is supplied with the correct voltage rating.
-  Verify that your mains connection is capable to satisfy the power ratings of the device.
-  Do not spill water or other liquids into or on the unit.
-  Do not use this unit if the electrical power cord is frayed or broken.
-  Do not remove the cover. Removing the cover will expose you to potentially dangerous voltage.
-  No naked flame sources such like lighted candles should be placed on the amplifier.

Contact the authorized centre for ordinary and extraordinary maintenance.

Speaker damage



Martin Audio MA2.8Q amplifiers are among the most powerful professional amplifiers available and are capable of producing much more power than many loudspeakers can handle. It is the user's responsibility to use suitable speakers with the amplifier and to use them in a sensible way that will not cause damage.

Martin Audio will not be responsible for damaged speakers. Consult the speaker manufacturer for power-handling recommendations.

Even if you reduce the gain using the amplifier's front panel attenuation controls, it is still possible to reach full output power if the input signal level is high enough. A single high-power crescendo can damage high-frequency drivers almost instantaneously, while low-frequency drivers can usually withstand very high, continuous power levels for a few seconds before they fail. Reduce power immediately if you hear any speaker "bottoming out" - harsh pops or cracking distortion that indicate that the speaker voice coil or diaphragm is striking the magnet assembly.

Martin Audio recommends that you use amplifiers of this power range for more headroom (cleaner sound) rather than for increased volume.



Speaker output shock hazard

A Martin Audio amplifier is capable of producing hazardous output voltages. To avoid electrical shock, do not touch any exposed speaker wiring while the amplifier is operating.

This manual contains important information on operating your Martin Audio amplifier correctly and safety. Please read it carefully before operating your amplifier. If you have any questions, contact your Martin Audio dealer.

Introduction

The totally new Martin Audio MA2.8Q amplifier technology has changed the way the world looks at professional audio amplification. No other amplifiers come close for applications demanding high power and long term reliability. Thanks to amazing reductions in heat output along with reductions in weight and the specific high output power, MA2.8Q amplifiers can be used in an unlimited range of applications such as concert touring, opera houses, theatres, churches, cinema, theme parks, television sound stages and stadiums.

More sound and less weight

Compared to a conventional amplifier, Martin Audio MA2.8Q technology offers very high efficiency and delivers more power to the loudspeakers with greatly reduced heat dissipation. This greater efficiency enables dimensions, weight and power consumption to be reduced. The output stages of the amplifiers typically run at 95% efficiency, dissipating only 5% of the input energy as heat.

One of the most interesting characteristics is that MA2.8Q efficiency is almost independent of output level. Conventional amplifiers achieve their best efficiency only at full rated power output. Since standard music has an average power density of 40% of the maximum level, conventional amplifiers can easily generate 10 times more heat than MA2.8Q amplifiers for the same volume of sound.

Superior Sound-Sonic Accuracy

Crystal-clear highs and a tight, well-defined low end: the most accurate reproduction of an audio signal. Patented design features ensure very high performance over parameters such as distortion, frequency response, slew rate, power bandwidth and dumping factor.

Totally Digital with High Reliability

The MA2.8Q series is based on PWM technology that has been used for 30 years or more in power supplies and inverters. PWM provides high reliability, small size, low weight and high efficiency. A PWM converter works as a high frequency sampler, converting the variable amplitude (audio) signal into an impulse sequence with average value equal to the audio input.

MA2.8Q amplifiers use very high sampling frequencies to obtain high performances across the audio band.

Compact & Lightweight

Martin Audio MA2.8Q amplifiers offer incredibly compact dimensions are very lightweight making them excellent for applications where space and weight saving are important. They also offer excellent ease of use.

The Show Always Goes On

The MA2.8Q is completely protected against every possible error in operation and are designed to work under every condition. They will deliver maximum power with maximum safety and increased long-term reliability. Anticipating potential problems at the design stage means your show always goes on!

1 Installation and operation

1.1 Unpacking

Carefully open the shipping carton and check for any noticeable damage.

Every Martin Audio amplifier is completely tested and inspected before leaving the factory and should arrive in perfect condition. If you find any damage, notify the shipping company immediately. Be sure to save the carton and all packing materials for the carrier's inspection.

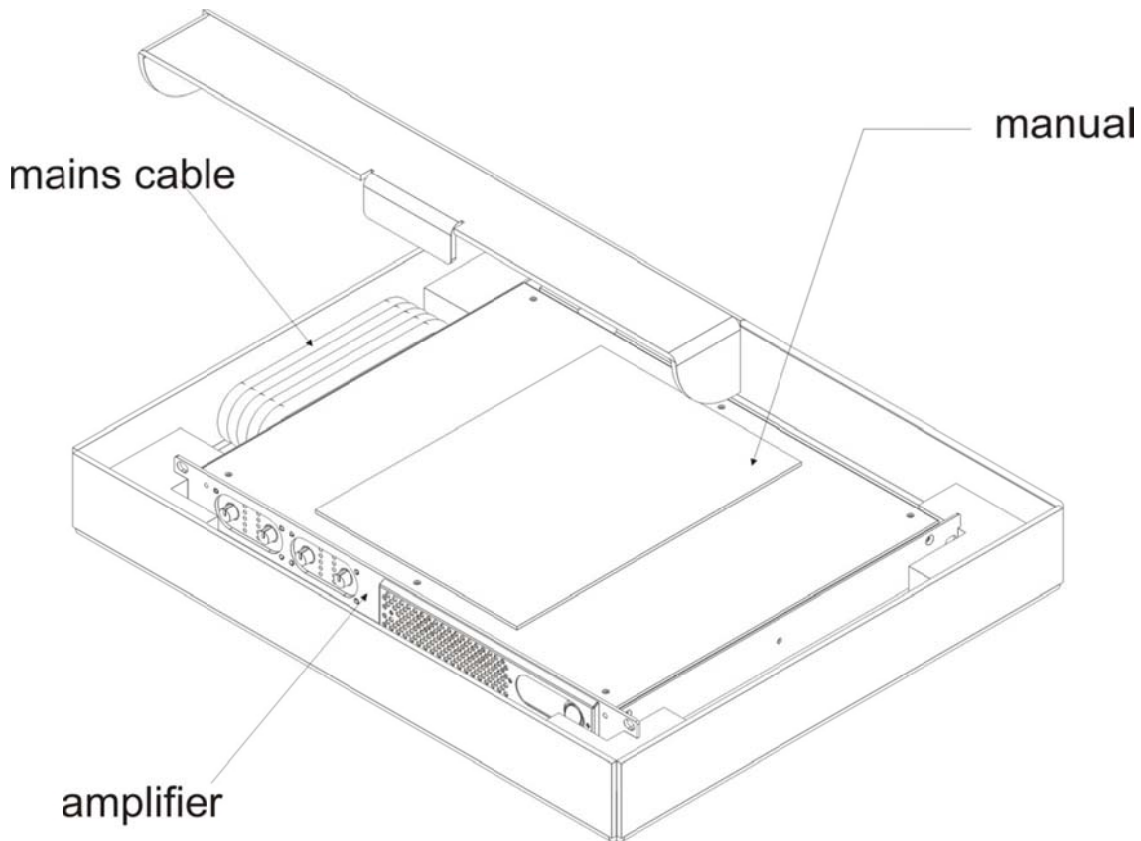

1.2 Mounting

The MA2.8Q amplifiers will mount in a standard 19" rack. Four front panel mounting holes are provided. Rear support mounting holes are also provided. These should always be used to support the weight of the amplifier at the rear in a 19" rack.

Your MA2.8Q amplifier uses a forced-air cooling system to maintain a low, even operating temperature. Drawn by an internal fan, air enters through the slots in the front panel and courses over and through components. The MA2.8Q series amplifiers feature an "intelligent" variable-speed DC fan which is controlled by heat sink temperature sensing circuits: the fan speed will increase only when the temperature of either heat sink requires it, which keeps fan noise to a minimum and helps cut dust accumulation inside. Under extreme thermal load, the fan will force a very large volume of air through the heat sinks.

If either heat sink gets too hot, its sensing circuit will reduce the output power. If the amplifier overheats, another sensing circuit shuts down its circuit to cut off power until it cools to a safe temperature. The exhaust cooling air is forced out through the rear of the chassis (see below), so make sure there is enough space around the sides of the amplifier to allow the air to escape. If it is rack mounted, make sure the exhaust air can flow without resistance. If you are using a rack with closed backs, there must be at least one standard rack space of opening in the front of the rack for every four amplifiers. Amplifiers may be stacked directly on top of each other (no space needed between units), starting from the bottom of the rack.

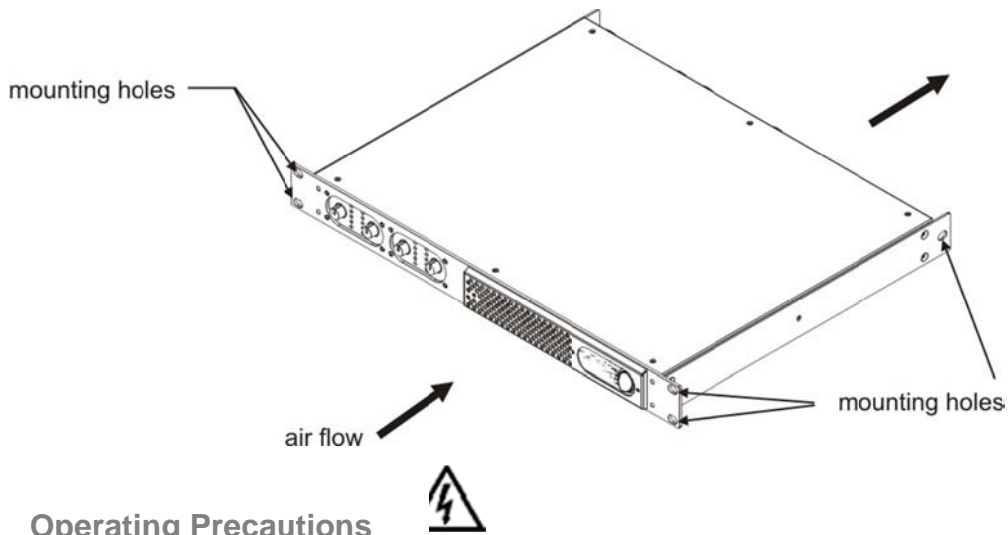

1.3 Operating Precautions

Make sure the AC mains voltage is correct and is the same as that printed on the rear of the amplifier. Damage caused by connecting the amplifier to improper AC voltage is not covered by the warranty. Make sure the power switch is off before making any input or output connections.

It is always a good idea to have the gain controls muted during power-up to prevent speaker damage particularly if there is a high signal level at the inputs.

Whether you purchase them or build them yourself, use good quality input and speaker cables. Most intermittent problems are caused by faulty cables. Use good quality connectors and cable along with good soldering technique to ensure trouble free reliability.

1.4 AC Main connection

Warning: before connecting to mains be sure that the amplifier is set to the correct mains voltage. The AC Main connection is made via the IEC type connector on the rear panel. The picture below shows the connection to the amplifier. Be sure that your AC mains power source has the requirements indicated in this manual. The amplifier is a resistive load for the mains network, minimizing the reactive power and the harmonic distortion on the current. The system allows performance to be maintained even in circumstances of varying the mains voltage. **Is important to connect the ground for safety, do not use adapters that disable the ground connection.**

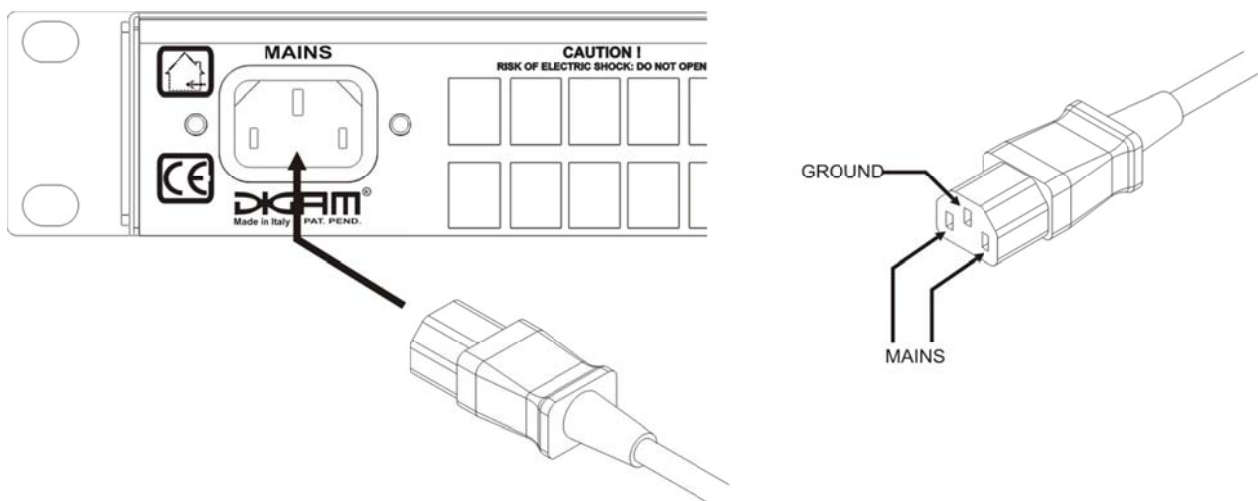

1.5 Connecting Inputs

Input connections are made via the 3-pin XLR-female on the rear of the amplifier.

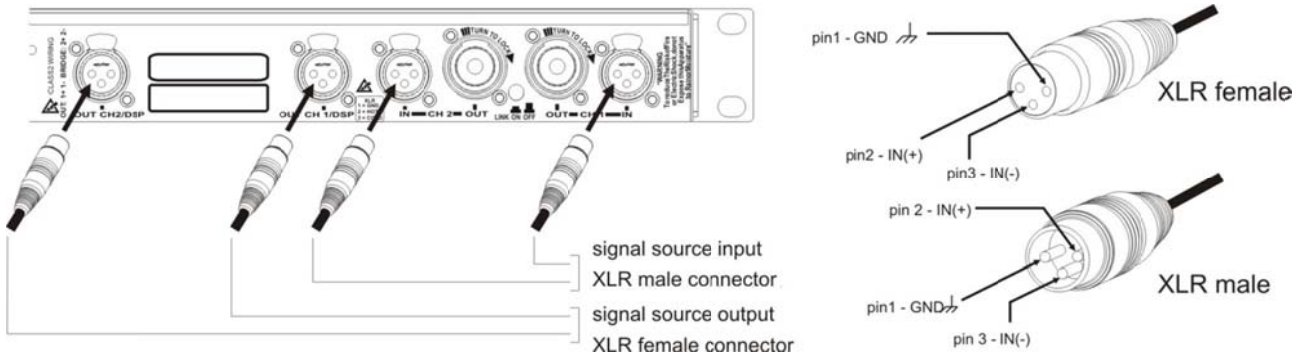

The figure below shows the connection of analog input for balanced and unbalanced line. You can use either configuration, but you must consider that unbalanced long lines can introduce noise in the audio system.

The Link switch located in the rear panel is for direct paralleling the rear input connectors. You can use the remaining input connector to carry signal to other amps.

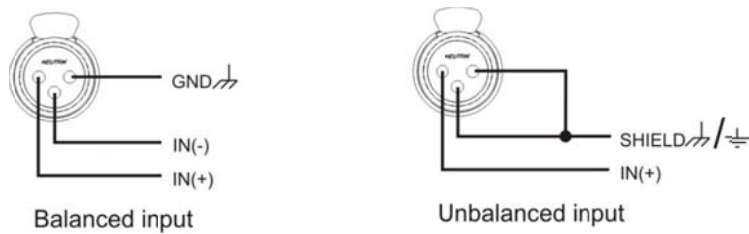

1.6 Connecting Outputs

Warning: there are lethal voltages at the loudspeaker connectors when the amplifier is turned on. To prevent any damages turn the amplifier off before connecting the loudspeaker.

Output connectors are made via Neutrik Speakon connectors. Consult the wire gauge chart to find a suitable wire gauge to minimize power and damping factor losses in the speaker cables. The outputs can also work in bridge mode. In normal stereo or linked mono mode, for each channel 1+ of the Speakon connector is the positive output and the 1- pin of the Speakon should be treated as the negative output.

Note: Channel B & D are run out of phase internally, corrected by reversing the connections from the amplifier output to the output connector, Channel A & C are run in phase. By having channel A and B and C and D operating in opposite polarity, the energy storage in the power supply is more efficient. This is significant for signals below 100Hz (sub bass etc.) and improves the power bandwidth.

Be sure to use balanced inputs on all measurement equipment (including oscilloscope probes) if you are bench testing.

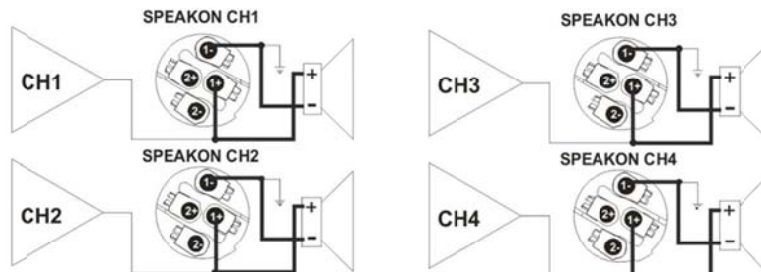
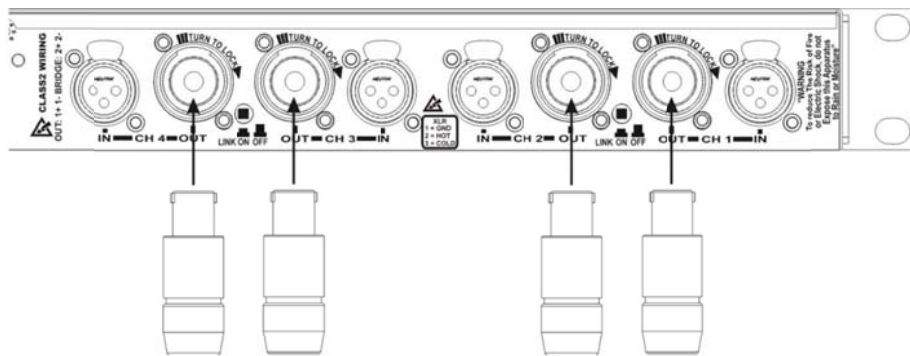

stereo mode:- speaker connections 1+/1-

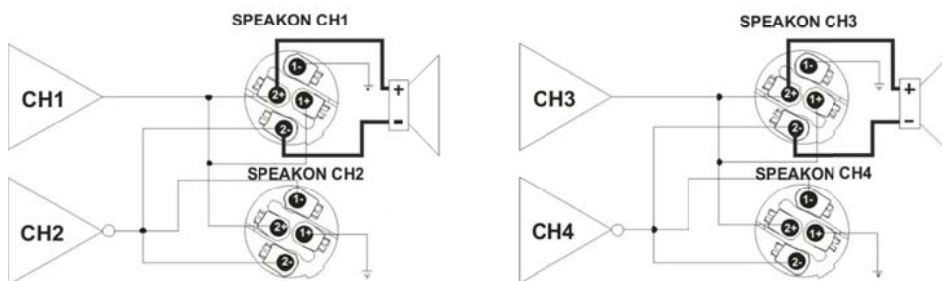

bridge mode:- speaker connections 2+/2-

Note: in Bridge mode the link switch must be switched to “on” and the gain controls of both channels must be set to the same level

2 Setup and settings

2.1 Introduction

The figure right shows the front panel of the MA2.8Q Amplifier.

The front panel controls and indicators give the user total control and detailed information about the status of the amplifier. The gain control uses a logarithmic scale from $-\infty$ to +32dB.

Read the instructions below carefully which will explain the many functions of the amplifier.



2.2 The LED indicators

The figure below shows the front panel of channels 1 And 2 of the MA2.8Q. The clip LED, when lighting, indicates the clipping state for the output stage of the corresponding channel. The signal, -18dB and -6dB LEDs operate as V-meter and the signal LED is illuminated when the signal is present in the input stage of the correspondent channel. The "ready" LED, when illuminated, indicates that the start-up time after power-on is finished and the amplifier is ready to use. The "temp" LED, when lit, indicates that the output stage of the corresponding channel is reducing the output power due to an over-heated state. The controls and indicators on channels 3 and 4 are identical.

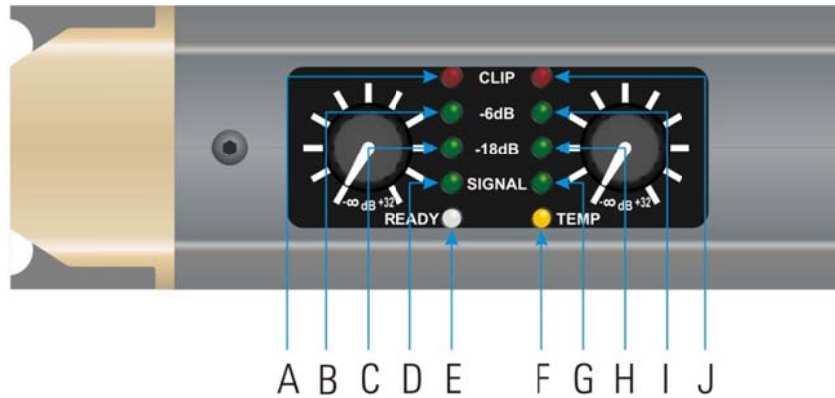

- | | |
|--|---|
| <ul style="list-style-type: none"> A - Clipping and protection indicator channel 1 B - -6dB output level indicator channel 1 C - -18dB output level indicator channel 1 D - Signal presence indicator channel 1 E - Ready indicator | <ul style="list-style-type: none"> F - Over-temperature indicator G - Signal presence indicator channel 2 H - -18dB output level indicator channel 2 I - -6dB output level indicator channel 2 J - Clipping and protection indicator channel 2 |
|--|---|

3 Protection

3.1 Turn-On-Turn-Off muting

For about four seconds after turn-on, and immediately at turn-off, the amplifier outputs are muted.

3.2 Short circuit protection

A short circuit protection system safeguards the amplifier's output transistors under short circuits and other stressful loads. It is completely inaudible when inactive. In the event of a short circuit condition, the red LED will be illuminated. The amplifier protection has an auto reset mode which will attempt to reset the amplifier for normal use after 2 seconds. If the short circuit is still present the amplifier will attempt to reset every 2 seconds until the short is removed.

3.3 Thermal protection

The MA2.8Q amplifier uses a continuously variable speed fan to assist cooling (the fan speed changes in response to the amplifier's cooling requirements). If the heatsink temperature reaches approximately 75°C, the "TEMP" LED illuminates and the output power is reduced to prevent damages to the output stage. If the temperature rises above 85°C the thermal sensing circuitry will mute each channels power section. Once the heatsink has cooled below 85°C the amplifier will automatically un-mute but the TEMP LED will remain lit until the temperature has dropped to 75°C. It is possible to reduce the temperature reducing the output power.

3.4 DC fault protection

If DC or excessive subsonic energy appears at a channel output, an instantaneous protection circuit will mute both channels of the amplifier. The amplifier shutdown is used instead of speaker relays, thereby improving the damping factor and reliability of the MA2.8Q.

3.5 Input / Output protection

An ultrasonic network decouples RF from the outputs and keeps the amplifier stable with reactive loads.

4 User Maintenance

4.1 Cleaning

Disconnect the amplifier from the AC main source first; use a soft cloth and mild non-abrasive solution to clean the faceplate and chassis.

4.2 Service

There are no user-serviceable parts in your MA2.8Q amplifier. Refer servicing to qualified technical personnel.

If your MA2.8Q amplifier needs repair, contact your Martin Audio dealer or distributor.

4.3 Dust removal

Particularly in dusty environments, the front filters clog with dust and dirt after prolonged use, this will interfere with cooling. You may use compressed air to remove the dust from filters.

To remove air filters for more comprehensive cleaning, unscrew the retaining screws and pull the covering grill forward.

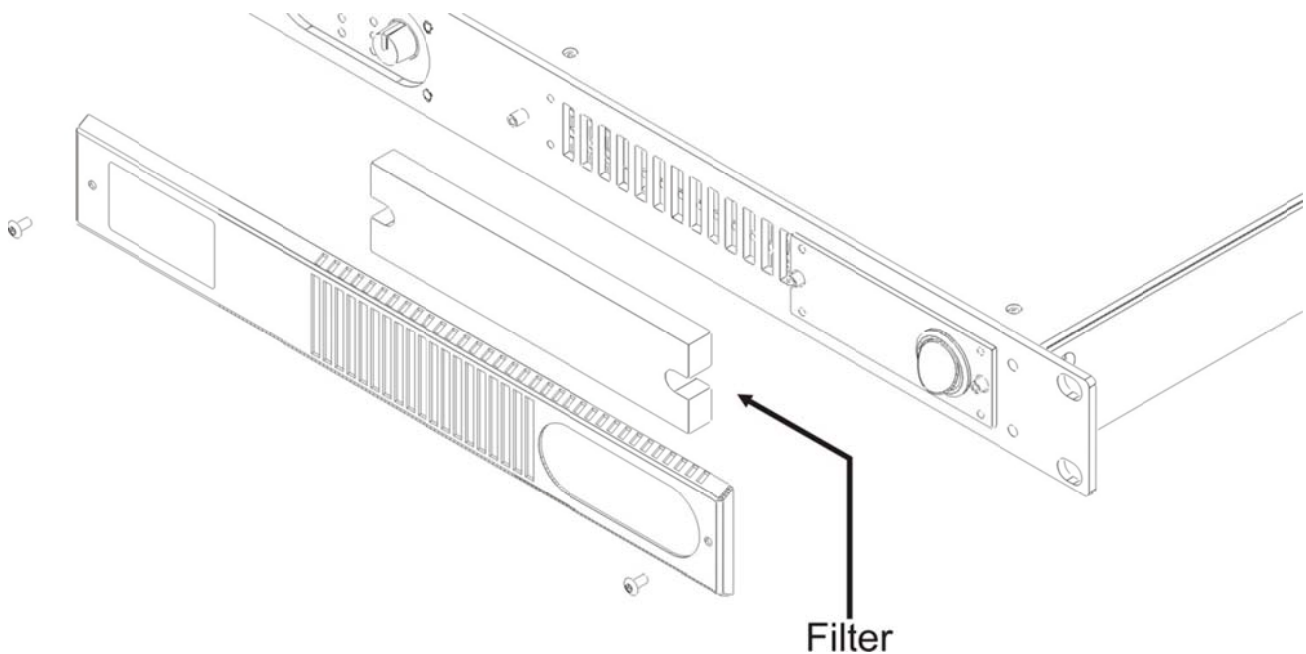

5 Warranty

Martin Audio **MA2.8Q** is warranted against manufacturing defects in materials or craftsmanship over a period of 3 (three) years from the date of original purchase.

During the warranty period Martin Audio will, at its discretion, either repair or replace products which prove to be defective provided that the product is returned in its original packaging, shipping prepaid, to an authorised Martin Audio service agent or distributor.

Martin Audio Ltd. cannot be held responsible for defects caused by unauthorised modifications, improper use, negligence, exposure to inclement weather conditions, act of God or accident, or any use of this product that is not in accordance with the instructions provided by Martin Audio. Martin Audio is not liable for consequential damages.

This warranty is exclusive and no other warranty is expressed or implied. This warranty does not affect your statutory rights.

7.2 Thermal Dissipation

Martin Audio MA2.8Q									
Level	Load	Rated Power	AC Mains		Out	Watt		Thermal Dissipation	
			230V AC	115V AC		In	Dissipated	BTU/hr	Kcal/hr
Switch in off position*			0.13	0.09	0	1.71	1.71	5.8	1.5
Power on, amplifier in idle mode			0.2	0.4	0	35	35	119	30
		Watt	Ampere		Watt			BTU/hr	Kcal/hr
Pink Noise (1/8 rated power)	8Ω / Stereo	4 x 360	1.3	2.6	180	225	100	341	86
	16Ω / bridged	2 x 720							
	4Ω / stereo	4 x 700	2.2	4.4	350	438	142	486	123
	8Ω / bridged	2 x 1400							
	2Ω / stereo	N/A	N/A	N/A	N/A	N/A	N/A	N/A	N/A
	4Ω / bridged	N/A							
Pink Noise (1/4 rated power)	8Ω / Stereo	4 x 360	2.3	4.5	360	450	145	494	125
	16Ω / bridged	2x 720							
	4Ω / stereo	4 x 700	4.1	8.2	700	875	230	784	198
	8Ω / bridged	2 x 1400							
	2Ω / stereo	N/A	N/A	N/A	N/A	N/A	N/A	N/A	N/A
	4Ω / bridged	N/A							

*Power absorption with amplifier switched off is not zero because to comply with EN60065/IEC 60065:2001-12 all amplifier circuitry must include a “bleed” resistor across the incoming AC mains power to discharge residual current to prevent the risk of shock from an amplifier disconnected from the mains.

7.3 Specification

POWER REQUIREMENTS

Power supply.....	115-230V (-15%, +15%) (50/60Hz) 800VA
Operating temperature	0°C to 45°C
Weight.....	7.3Kg (16.1 lbs)
External dimensions	
Width.....	Standard 19" Rack: 483mm (19")
Depth.....	358mm (14")
Height.....	1 Rack Unit: 44mm (1.75")

AUDIO SECTIONS

Bandwidth (1W, 8Ohm).....	10Hz, 30KHz
Damping factor (8Ohm).....	at 100Hz > 500
Slew Rate (8Ohm).....	>50V/μS (input filter bypassed)
S/N ratio.....	>112dB/A (20Hz to 20KHz)
Distortion THD.....	< 0.05% from 1W to full power (typically <0.01%)
Intermodulation SMPTE	< 0.05% from 1W to full power (typically <0.01%)
Intermodulation DIM 30.....	<0.02% from 1W to full power (typically <0.005%)
Inputs.....	Balanced to ground, XLR female with parallel Male XLR
Impedance.....	10KOhm each leg balanced to ground
Gain	32dB
Outputs.....	Neutrik 4-pole Speakon connectors (pins 1+ 2+ paralleled, 1- 2- paralleled)

OUTPUT SPECIFICATIONS

Output Power	
EIAJat 1KHz, 1% THD	
8Ω Per Channel.....	360W
4Ω Per Channel.....	700W
16Ω Bridged.....	720W
8Ω Bridged.....	1400W

FEATURES

Indicators.....2 x 4 segment LED bargraph
 Over-temperature forecasting, thermal protection, short circuit protection, overload output protection, temperature controlled air cooling system, clip limiter and permanent signal limiter, auto-reset system, parallel inputs switch, input signal presence LED.

7.4 Technical Drawing

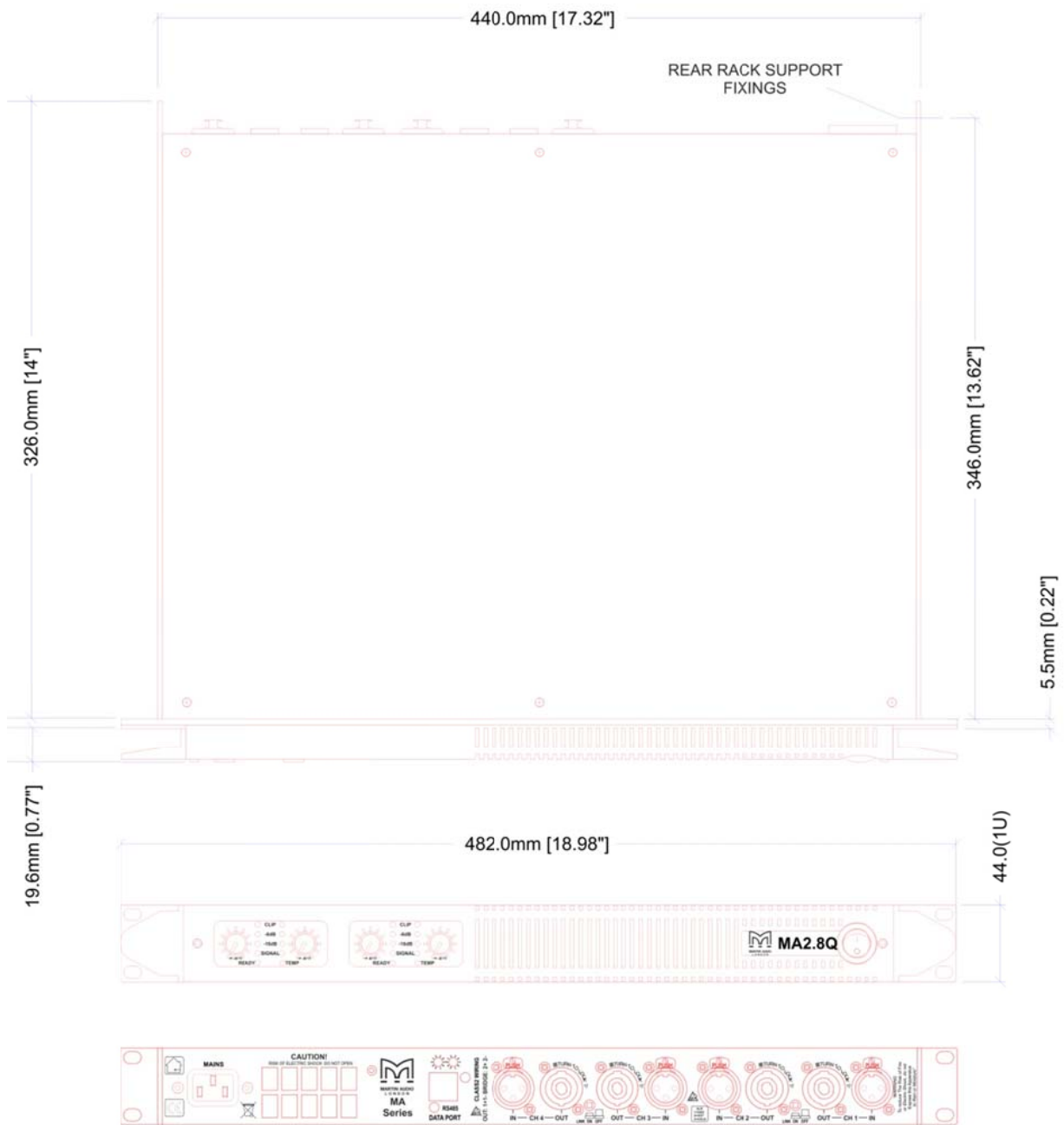

MA2.8Q

All information is Copyright © 2010 Martin Audio Ltd.