



TAKE THE STAGE

MARTIN AUDIO
STAGE MONITORS

MARTIN AUDIO LIMITED

CE

Unite Your Audience
The Martin Audio Experience





XE

STAGE MONITORS

Musicians benefit from an onstage environment where they sound great. Hearing their individual performance, as well as the overall sound of the other musicians with clarity, dynamism and presence is essential to a confident performance that unites the band onstage. This is the realm of the stage monitor — the vital bridge between the artist and the audience.

Martin Audio brings engineering innovation to high performance stage monitoring with the XE Series — setting a new reference in sonic excellence and defined coverage. Designed in consultation with leading monitor engineers and combining sleek, low-profile enclosures with unique Coaxial Differential Dispersion technology, the XE300 and XE500 deliver perfect monitor sound with a defined coverage pattern that allows the artist freedom of movement, while reducing overlap with adjacent monitors.

Coaxial Differential Dispersion technology allows the artist to stand directly over the monitor or further back, without significant changes in SPL or tonal balance. It produces the optimal coverage pattern over a listening plane at head-height and helps to contain the sound within that region.

Delivering definitive monitor sound, the visually-appealing XE Series enclosures present a low, camera-friendly profile, are easy to carry and manoeuvre, and feature built-in risers for situations that call for a steeper monitoring angle.

Designed as a complete system, compatible iKON Class D amplifiers maximise the capability of the monitor while ensuring both engineer and artist can be confident they will experience the same high level of consistent performance from an XE monitor anywhere in the world.





FEATURES

- Very high-SPL, compact two-way stage monitors
- Coaxial 'point source' performance
- Differential Dispersion™ technology for consistent coverage
- Defined, rectangular coverage plane at head-height
- Complete system with iKON amplifiers for consistent high performance
- Visually-appealing, low-profile plywood enclosures
- Built-in risers for steeper monitor angle when required
- Side panel rubber feet for extra protection when up-ended
- Easy to carry and manoeuvre
- M8 rigging inserts

COAXIAL DIFFERENTIAL DISPERSION™: THE IDEAL COMPACT MONITOR TECHNOLOGY

Coaxial Differential Dispersion technology combines the 'point-source' benefits of coaxial designs with the consistent coverage of Differential Dispersion technology. XE Series monitors feature Martin Audio's patented Coaxial Differential Dispersion drivers with an additional, patented, contour-moulded static third waveguide that increases the size of the horn mouth to maintain pattern control downwards and avoid spill outside the desired coverage area. Its rolled contour reduces diffraction and further improves pattern consistency at the lower end of the HF passband.

THE COAXIAL ADVANTAGE

Non-coaxial two-way monitors can suffer from uneven frequency response off-axis because the outputs of the LF and HF sections interfere with each other, causing cancellations off-axis, depending on the listening position. This is most noticeable close to the loudspeaker in the all-important crossover region — which lies right in the middle of the vocal band.

In contrast, coaxial monitors can achieve 'point-source' summation of the LF and HF sections at all positions off-axis, even close-up. Other advantages of coaxial designs are that they remove the need for left and right-handed versions and are inherently more compact.

Significantly, until now one disadvantage of conventional coaxial devices has been high frequency beaming, where the high frequency dispersion reduces as the frequency increases. This is primarily because conventional coaxial devices channel high frequencies through a narrow tube in the pole-piece of the magnet system. XE Series coaxial drivers overcome this by incorporating an innovative static waveguide in the centre of the driver that merges seamlessly with the unique cone shape — maintaining the dispersion pattern out to very high frequencies.



• XE Driver

THE DIFFERENTIAL DISPERSION™ ADVANTAGE

A Differential Dispersion horn has a 3D trapezoid dispersion pattern which distributes sound over a plane at the performer's head-height more evenly than a system with a conventional, fixed-dispersion $X^\circ \times Y^\circ$ type horn, which produces an imperfect coverage pattern which misses out some areas — particularly side areas close to the monitor.

In contrast, a Differential Dispersion monitor produces a well-defined, near-rectangular coverage pattern at head-height and wide horizontal coverage is achieved when standing very close to the monitor. As the artist moves further back, the dispersion narrows, increasing the SPL to compensate for the increased distance from the monitor. The frequency response is unchanged, so the artist hears essentially the same sound balance and level wherever they stand within the coverage area.

The consistency in frequency response and SPL — both close to the monitor and further back — is exceptional. The well-defined and tight horizontal coverage also allows monitors with different mixes for individual performers to be placed closer together on stage.

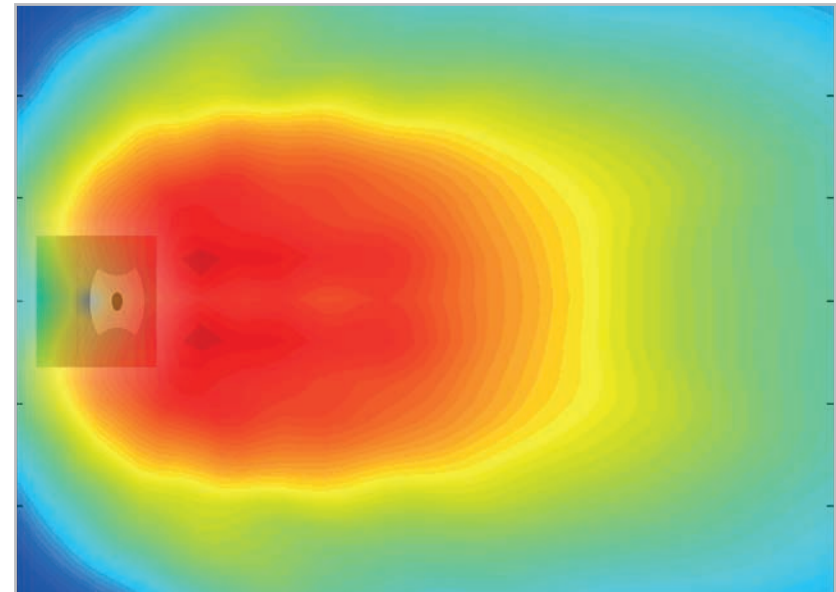

- XE500 SPL @ 6.3kHz over a 3 x 4m plane at head height
Each contour represents 0.2dB change; yellow is -6dB

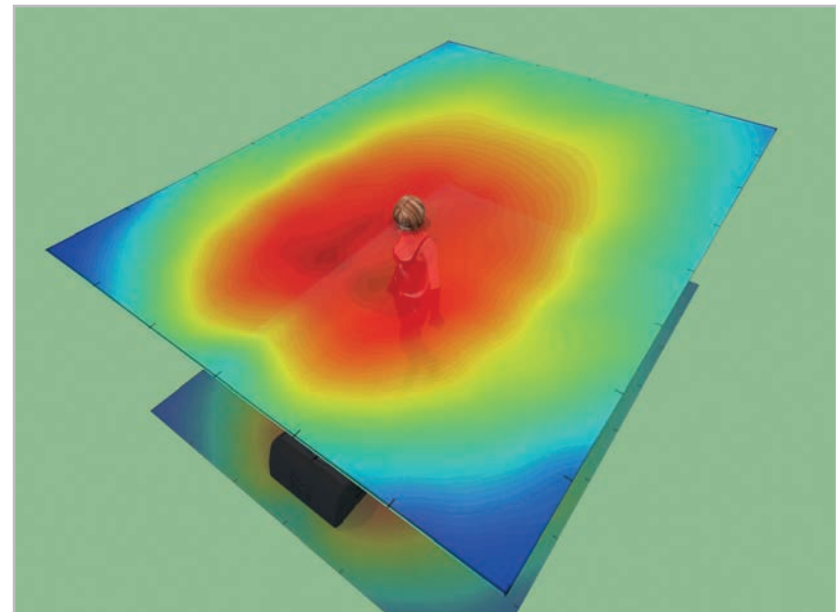

- Well-defined rectangular coverage pattern
Artist can stand over monitor or further back without significant change in SPL



XE300

The XE300 is the definitive, high-performance compact monitor. It features a high-specification 12" (300mm) LF /1.4" exit HF Coaxial Differential Dispersion driver to deliver perfect sound over the artist's listening plane. The LF driver section has a 3" (75mm) voice coil and efficient motor with an aluminium demodulating ring to minimise distortion, while the HF driver utilises a 1.4" (35mm) exit HF compression driver with a 3" (75mm) pure titanium diaphragm.

Its unique Coaxial Differential Dispersion technology produces a horizontal coverage pattern which varies from 60° when the performer is directly over the monitor, narrowing to 30° further back. This narrowing delivers a near-rectangular coverage plane at head-height to maintain the sound level and balance independent of distance from the monitor.

The XE300 enclosure is constructed from multi-laminate birch ply, with integral ergonomic handles and finished with a hard-wearing paint. A strong, perforated steel grille with an acoustically transparent cloth backing provides protection for the Coaxial Differential Dispersion driver, while moulded feet on the base prevent movement onstage with additional rubber feet on the side panels providing added protection if the monitor is upended when carrying.

Frontal reflex ports couple with the floor to increase LF output and inbuilt risers can be used to increase the monitoring angle for longer-throw applications.



XE300
12" LF
PEAK SPL 140dB



XE500
15" LF
PEAK SPL 143dB

XE500

Combining very high output capability with exceptional sonic performance, coverage control and consistency, the XE500 is the ultimate, high SPL stage monitor. Its Coaxial Differential Dispersion drive unit comprises a powerful 15" (380mm) LF driver with a 3.5" (89mm) voice coil, and a 1.4" (35mm) exit HF compression driver with a 3" (75mm) pure titanium diaphragm. Both drivers feature powerful neodymium magnet structures to maximise performance and reduce weight.

Utilising Coaxial Differential Dispersion technology, the XE500's horizontal coverage varies from 60° directly over the monitor, narrowing to 30° further back. This not only maintains the sound level and balance independent of distance from the monitor, it produces a well-contained coverage 'corridor' at head-height. A patent-pending, contour-moulded static third waveguide greatly increases the effective size of the horn mouth to extend pattern control down to 500Hz, reducing sound spill outside the 'corridor'.

The XE500 enclosure is constructed from multi-laminate birch ply, with integral ergonomic handles and finished with a hard-wearing paint. A strong, perforated steel grille with an acoustically transparent cloth backing provides protection for the Coaxial Differential Dispersion driver, while moulded feet on the base prevent movement onstage with additional rubber feet on the side panels providing added protection if the monitor is upended when carrying.

Frontal reflex ports couple with the floor to increase LF output and inbuilt risers can be used to increase the monitoring angle.

Easy to manoeuvre, its exceptional performance and 'corridor' coverage make the XE500 the new definitive, high SPL stage monitor.

THE COMPLETE PACKAGE

XE Series monitors are designed as a complete system with compatible iKON Class D Amplifiers, offering a unique combination of power and audio performance seamlessly combined with advanced DSP, proprietary VU-NET™ software control and Dante™ digital audio networking. State of the art components and a finely optimised design results in generous power reserves that ensures pristine sound quality is maintained even under the most extreme conditions. As well as maximising the capability of the monitor, this ensures that the monitor engineer and artist can be confident that they will experience this same high level of consistent performance from an XE monitor anywhere in the world.

iKON



XE SERIES VOICING

A stage monitor has distinct sonic requirements and voicing is critical. Firm bass punch is essential to counter the low frequency wash emanating from other sources and the room. The monitor also needs clarity and an element of 'bite' that will cut through to the artist without being overly harsh. XE Series monitors have been designed with input from leading monitor engineers to deliver the ideal subjective voicing and coverage characteristics that will overcome the onstage acoustics and enable artists to fully immerse themselves in their performance.



TECHNICAL SPECIFICATIONS

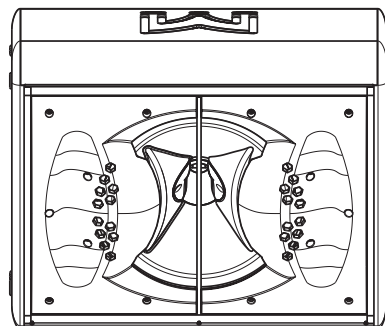

XE300

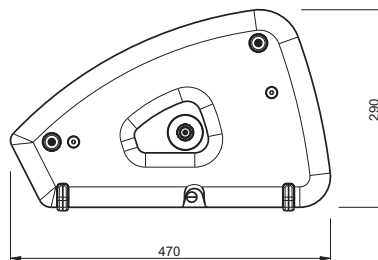
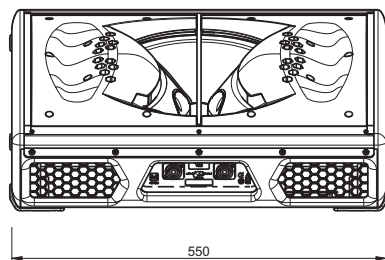

XE300

TYPE	Two-way, bi-amp/passive, Coaxial Differential Dispersion stage monitor
FREQUENCY RESPONSE (3)	67Hz-18kHz \pm 3dB -10dB @ 55Hz
DRIVERS	LF: 12" (300mm)/3" (75mm) voice coil, dual-gap neodymium motor system HF: 1.4" (35mm) exit/3" (75mm) voice coil, titanium dome compression driver
RATED POWER (2)	LF: 350W AES, 1400W peak HF: 80W AES, 320W peak
SYSTEM AMPLIFIER	iKON iK41 / iK42 / iK81
MAXIMUM SPL (9)	Bi-amp: 140dB peak. Passive: 139dB peak
NOMINAL IMPEDANCE	LF/FR: 6 ohms, HF: 8ohms
DISPERSION (-6dB)	60-30° horizontal, 90° vertical
CROSSOVER	1.1kHz
ENCLOSURE	Birch/beech ply and hardwood
FINISH	Textured black paint
PROTECTIVE GRILLE	Black perforated steel with scrim cloth backing
BAFFLE ANGLE	27.5° (40° with risers)
CONNECTORS	4 x NL4 type
PIN CONNECTIONS	LF/FR: 1+/-, HF: 2+/-
FITTINGS	2 x pocket handles Protective rubber feet on base and sides Built-in risers 4 x M8 inserts
DIMENSIONS	(W) 550mm x (H) 290mm x (D) 470mm (W) 21.7ins x (H) 11.4ins x (D) 18.5ins
DIMENSION INCL FEET	(W) 556mm x (H) 293mm x (D) 470mm (W) 21.9ins x (H) 11.5ins x (D) 18.5ins
WEIGHT	19kg (41.9lbs)
ACCESSORIES	Eyebolts

Notes

- (1) Measured on-axis in half (2pi) space at 2 metres, then referred to 1 metre.
- (2) AES Standard ANSI S4.26-1984.
- (3) Measured in half (2pi) space at 2 metres with 1 watt input, using band limited pink noise, then referred to 1 metre.
- (4) Measured in half (2pi) space at 2 metres using band limited pink noise, then referred to 1 metre.
- (5) Measured on-axis in open (4pi) space at 2 metres, then referred to 1 metre.
- (6) Measured in open (4pi) space at 2 metres with 1 watt input, using band limited pink noise, then referred to 1 metre.
- (7) Measured in open (4pi) space at 2 metres using band limited pink noise, then referred to 1 metre.
- (8) Measured in open (4pi) space at 2 metres with 2.83v input, using band limited pink noise, then referred to 1 metre.
- (9) Calculated at 1 metre.
- (10) Measured in half (2pi) space at 2 metres with 2.83V input, using band limited pink noise, then referred to 1 metre.

XE500

TYPE	Two-way, bi-amp, Coaxial Differential Dispersion stage monitor
FREQUENCY RESPONSE (3)	62Hz-18kHz \pm 3dB -10dB @ 45Hz
DRIVERS	LF: 15" (380mm)/3.5" (89mm) voice coil, dual-gap neodymium motor system HF: 1.4" (35mm) exit/3" (75mm) voice coil, titanium dome compression driver
RATED POWER (2)	LF: 550W AES, 2200W peak HF: 80W AES, 320W peak
SYSTEM AMPLIFIER	iKON iK42
MAXIMUM SPL (9)	143dB peak
NOMINAL IMPEDANCE	LF: 4 ohms, HF: 8ohms
DISPERSION (-6dB)	60-30° horizontal, 70° vertical
CROSSOVER	1.1kHz active
ENCLOSURE	Birch/beech ply and hardwood
FINISH	Textured black paint
PROTECTIVE GRILLE	Black perforated steel with scrim cloth backing
BAFFLE ANGLE	30° (40° with risers)
CONNECTORS	4 x NL4 type
PIN CONNECTIONS	LF: 1+/-, HF: 2+/-
FITTINGS	2 x bar handles Protective rubber feet on base and sides Built-in risers 4 x M8 inserts
DIMENSIONS	(W) 635mm x (H) 364mm x (D) 583mm (W) 25.0ins x (H) 14.3ins x (D) 22.9ins
DIMENSIONS INCL FEET	(W) 641mm x (H) 367mm x (D) 583mm (W) 25.2ins x (H) 14.4ins x (D) 22.9ins
WEIGHT	29kg (63.9lbs)
ACCESSORIES	Eyebolts

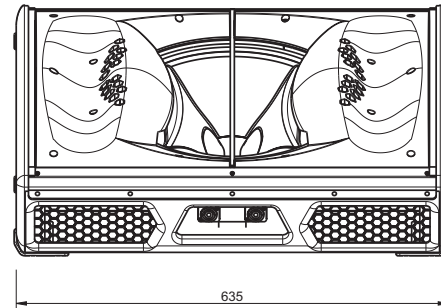
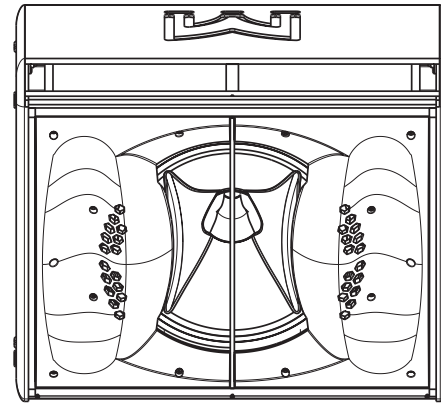

XE500

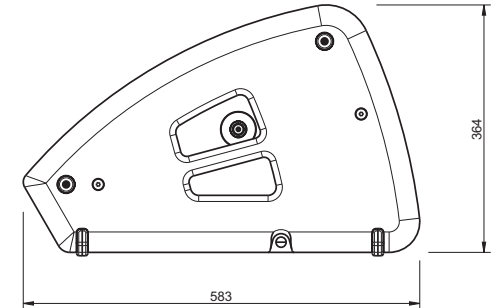



TAKE THE STAGE

Martin Audio Limited

Century Point

Halifax Road

Cressex Business Park

High Wycombe

Buckinghamshire

HP12 3SL

England

FOR SALES ENQUIRIES:

UK

Telephone: +44 (0)1494 535312

E-mail: info@martin-audio.com

NORTH AMERICA

Telephone: 323 381 5310

www.martin-audio.com

All information is Copyright © 2024 Martin Audio Ltd.

Martin Audio, the Martin Audio logo and Hybrid are registered trademarks of Martin Audio Ltd. in the United Kingdom, United States and other countries; all other Martin Audio trademarks are the property of Martin Audio Ltd. Dante™ is a trademark of Audinate Pty Ltd.



Unite Your Audience
The Martin Audio Experience

Version 2.0