

AVAILABLE IN CHINA ONLY

Blackline³

The Ultimate in Entertainment



Unite Your Audience
The Martin Audio Experience



Martin Audio was founded by the pioneering David Martin in London 1971, to manufacture touring loudspeakers for the rock bands of the time — including The Who, Supertramp and Pink Floyd. They were designed to improve the sound quality and enjoyment for the audience.

This focus upon the audience experience has remained ever since, and our design philosophy is built on the conviction that the correct sound characteristics should be inherent in the acoustic design, not dependent on subsequent electronic correction. This has provided a signature sound for Martin Audio loudspeakers and brought smiles to the faces of millions of people around the world.

No more so than in entertainment venues where our loudspeakers have graced legendary bars, clubs and restaurants from New York, London, Paris, Milan to Beijing. The world renowned Ministry of Sound in London, with its complement of Martin Audio speakers throughout the venue has won Best Club Sound System Design at the IDMA for four consecutive years from 2010 to 2013.

The cornerstone of Martin Audio's success has always been a commitment to quality, and we continue to invest in our British headquarters where our innovative and award-winning loudspeaker systems are designed and manufactured.



Blackline³

For over fifteen years, Martin Audio's Blackline loudspeaker systems have gained a worldwide reputation for performance, quality and reliability, and have graced the best bars and clubs from New York to London. With its brand status so revered, it is perhaps not surprising that in China, Martin Audio's Blackline Series is also seen as the leading loudspeaker system in the premium entertainment sector, and the guarantor of happy audiences and repeatedly busy venues.

Now, Martin Audio engineers have designed and developed the all-new Blackline 3 Series, combining elegant enclosures with unique Coaxial Differential Dispersion™ technology to deliver class-leading performance, fidelity and consistency.

With Blackline 3, the best just got better.





The Blackline 3 Series comprises the FX10, FX12 and FX15 two-way full range Coaxial Differential Dispersion systems, supported by the B18 and B218 subwoofers, and complemented by the FH3 high performance, all-horn, three-way system. The Coaxial Differential Dispersion technology employed in the FX10, FX12 and FX15 delivers more consistent audience coverage than systems with fixed dispersion $X^\circ \times Y^\circ$ horns — projecting more output to the rear of the audience to distribute sound evenly front-to-to-back, while having wide horizontal coverage close-up. Where the ultimate in performance and impact is required, the all-horn FH3 delivers very high SPLs for the most demanding venues.

Visually-appealing industrial design is a distinctive feature of the Blackline 3 Series. The FX10, FX12 and FX15 full-range enclosures can be used in either horizontal (landscape) or vertical (portrait) orientation, with rotation of the coaxial driver easily accomplished by removing the screw-free, protective grille. The curved shape of each full-range enclosure allows it to be bracket-mounted closer to a wall, for more discreet positioning, and integral M8 inserts are provided for eyebolt suspension. The FH3 adopts a horizontal format to facilitate suspension above head height by means of integral M10 inserts.

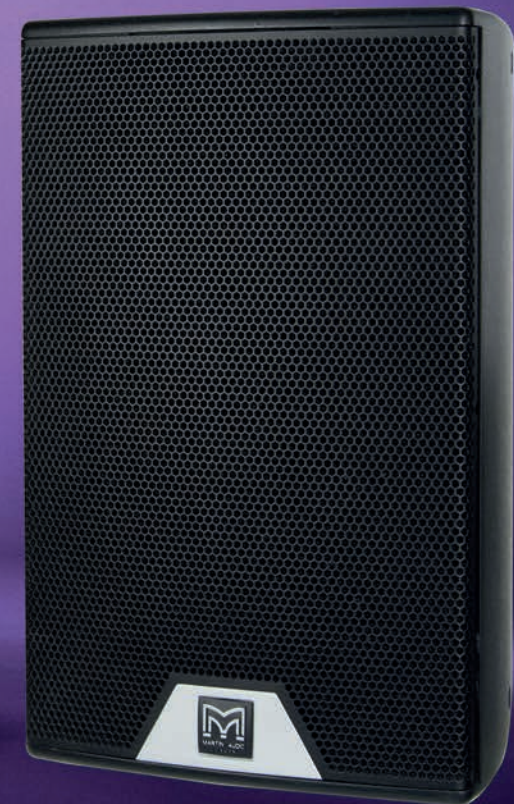
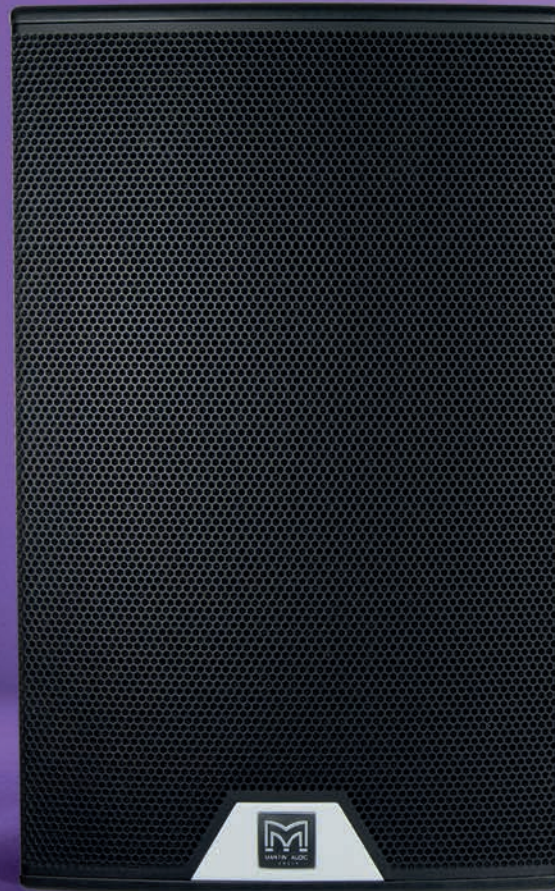

FX10/FX12/FX15 FEATURES

- Versatile, passive, two-way systems
- Coaxial 'point source' performance
- Differential Dispersion™ technology for consistent coverage
- Elegant wood fibre/polypropylene composite enclosures
- User rotatable coaxial drive units
- Vertical and horizontal mounting options
- Screw-free perforated steel grilles
- 8Ω nominal impedance
- Integral M8 inserts for eyebolt suspension

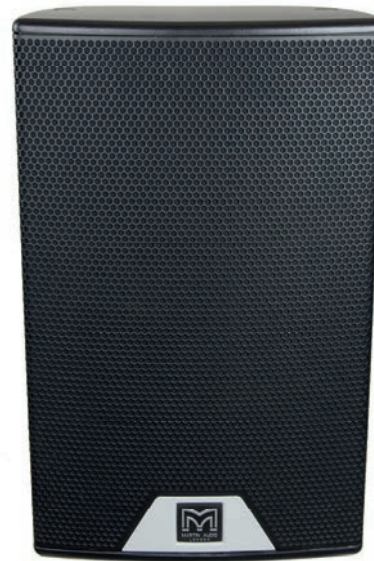

FX10



FH3 FEATURES

- All-horn loaded, three-way system
- 'Phase-ball' loaded midrange horn
- Hybrid® low frequency section
- Horizontal, low-profile format
- Very high SPL capability
- 8Ω nominal impedance (LF, MF+HF sections)
- Integral M10 inserts for eyebolt suspension



FH3

APPLICATIONS

- Live music clubs
- Music bars
- Nightclubs
- Premium KTV

COAXIAL DIFFERENTIAL DISPERSION™: THE BEST OF BOTH WORLDS

Blackline 3 combines the consistent coverage of Differential Dispersion technology with the 'point-source' benefits of coaxial designs. Blackline 3 FX10, FX12 and FX15 systems feature revolutionary, patent-pending Coaxial Differential Dispersion™ technology to deliver perfect sound to every member of the audience.

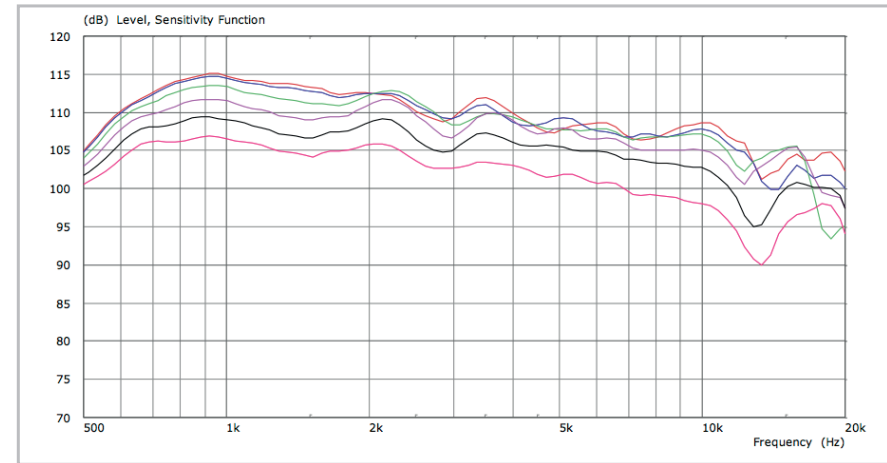

- 0/10/20/30/40/50 degree off-axis measurements of Blackline3 FX15 (wide-axis). Constant beamwidth maintained up to 20kHz.

THE COAXIAL ADVANTAGE

Non-coaxial systems can suffer from uneven frequency response in the crossover region because the outputs of the LF and HF sections interfere with each other, causing variations off-axis, depending on the listening position. This is especially true close to the loudspeaker.

In contrast, coaxial systems can achieve 'point-source' summation of the LF and HF sections at all positions off-axis, even close-up. This is one reason that coaxial devices are often used for nearfield applications such as studio monitoring.

Significantly, until now one disadvantage of conventional coaxial devices has been high frequency beaming, where the high frequency dispersion reduces as the frequency increases. This is primarily because conventional coaxial devices channel high frequencies through a narrow tube in the pole-piece of the magnet system. Blackline3 Series coaxial devices overcome this by incorporating an innovative static waveguide that merges seamlessly with the unique cone shape — maintaining the dispersion pattern out to very high frequencies.

THE DIFFERENTIAL DISPERSION™ ADVANTAGE

A Differential Dispersion horn has a 3D trapezoid dispersion pattern which covers a room more evenly than a conventional X° x Y° type horn.

With a conventional X° x Y° horn, the speaker is usually placed above head height and aimed towards the centre of the audience. This produces an imperfect coverage pattern which misses out some areas – particularly side areas close to the loudspeaker.

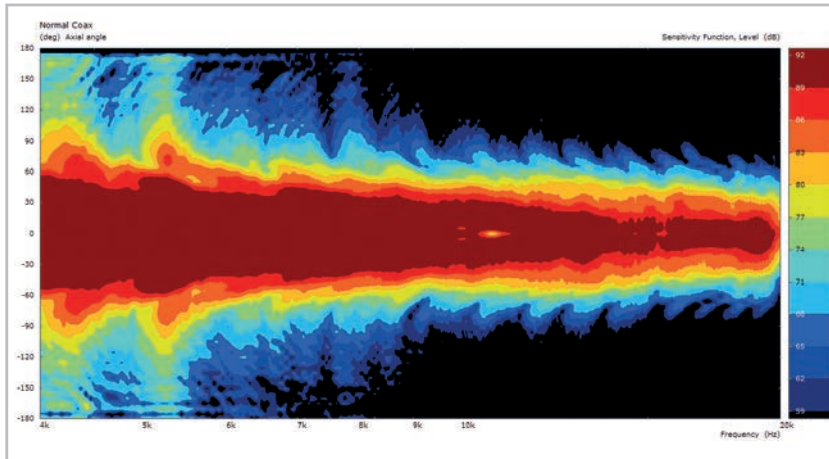

• Conventional coaxial beamwidth

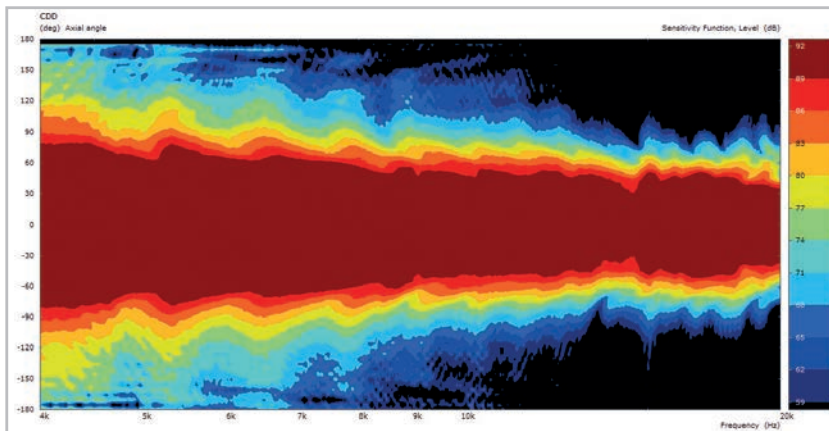

• Blackline3 beamwidth (horizontal)

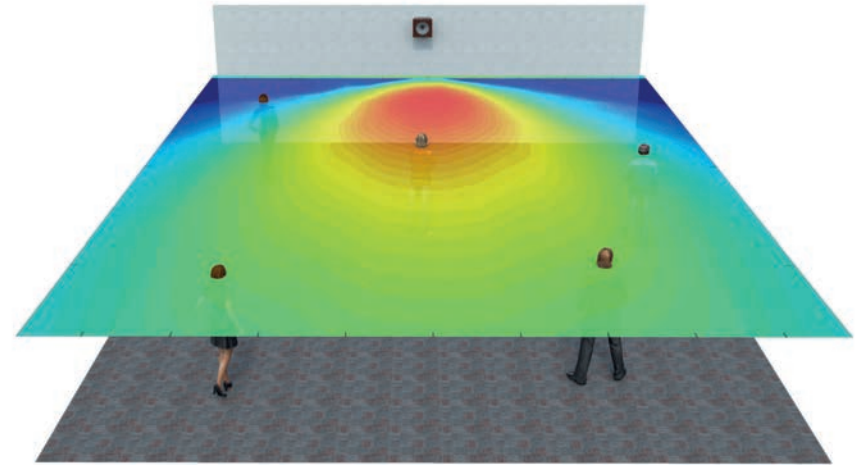

• Conventional coaxial

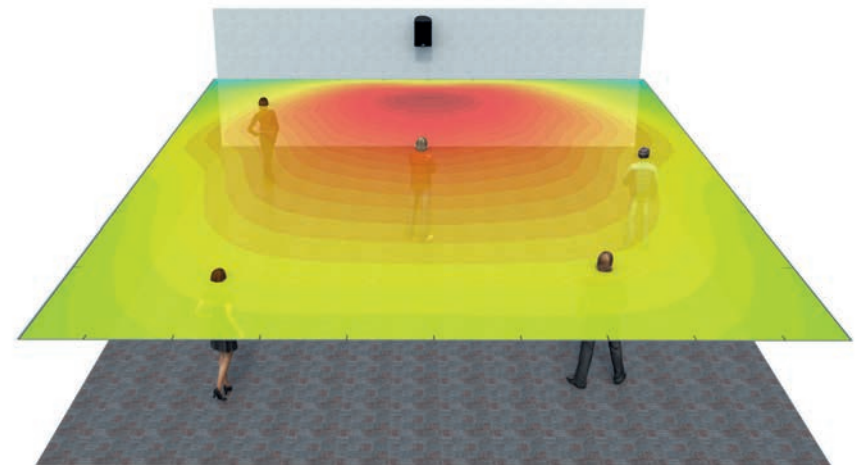

• FX12 DD coaxial

In contrast, a Martin Audio Coaxial Differential Dispersion system produces a rectangular coverage pattern to reach all corners of the audience, and wide horizontal coverage is achieved very close to the loudspeaker. Walking the room, the consistency in frequency response and SPL — both close to the loudspeaker and further back — is remarkable. The improved coverage close-up also means that FX10, FX12 and FX15 speakers can be spaced further apart in some instances, reducing overall speaker count.



FX10

The FX10 is a high performance yet very compact two-way passive loudspeaker system which utilises a 10" (250mm) LF/1" (25mm) exit HF Coaxial Differential Dispersion driver. The long-excursion LF driver has a 2.5" (63mm) voice coil and shares its magnet system with the coaxial HF section, which utilises a 1.4" (36mm) polyimide diaphragm.

Its small size gives no indication of its high output capability — it is uniquely placed to meet the foreground requirements of music bars and clubs that require upfront sound levels from a very compact enclosure. Use with a B18 or B218 subwoofer will enable the FX10 to operate as small dancefloor system that is remarkably powerful for its size.

Moulded in rigid UPM Formi composite, its distinctive curved enclosure enables the FX10 to be installed close to walls and ceilings.



FX12

The FX12 is a high performance, passive two-way system designed for premium entertainment applications. Featuring a high-specification 12" (300mm) LF drive unit and a 1" (25mm) exit compression driver, its Coaxial Differential Dispersion pattern delivers perfect sound over distances between 2 metres and 5 metres from the loudspeaker.

The LF driver has a 2.5" (65mm) voice coil and a high BL motor with an aluminium demodulating ring to minimise distortion. The HF compression driver utilises a 1.75" (44mm) polyimide diaphragm for extended high frequency response and features a phase-plug with a low-compression ratio to reduce non-linearity caused by high air pressure within the compression driver.

The FX12's enclosure is constructed from UPM Formi composite with a plywood speaker baffle and coated in black textured paint. Its steel grille is a spring-fit into the sides of the enclosure, eliminating the necessity for fixing screws and allowing easy access to the coaxial driver.



FH3

The new FH3 is a very high performance, all-horn, three-way system in a single, horizontally formatted, wide-bandwidth package aesthetically designed to complement the Blackline3 collection.

High quality and unique drivers deliver exceptional performance in all bands. The Hybrid® low frequency section comprises a horn-loaded 15" (380mm)/4" (100mm) voice coil ultra-long-excursion neodymium magnet driver that is also reflex loaded to extend the LF output to below the natural cut-off point of the horn. The LF driver features a water resistant cone and triple roll surround for increased excursion.

The mid-horn of the FH3 has a unique 'phase-ball' loading device which maintains the constant directivity characteristics of the horn at the upper end of its range. It is driven by a 10" (250mm) midrange driver with an aluminium demodulating ring for improved high-mid clarity and reduced distortion when driven hard. The 70° x 40° HF section of the FH3 features a neodymium 1" (25mm) exit compression driver with a polyamide diaphragm for high sensitivity and extended HF performance. The internal mid/high passive crossover allows this three-way system to be driven in a bi-amp configuration.

A Martin Audio DX1.5 and DX2 Electronic Controller are available to provide FH3 crossover and limiter facilities.

FX15

The FX15 is a very high-power, passive two-way system designed for professional installations that demand the ultimate in sonic performance from a single compact enclosure. It combines very high output capability with exceptional fidelity and coverage consistency.

It features a powerful 15" (380mm)/3" (75mm) voice coil LF drive unit, and a 1.4" (35mm) exit HF compression driver with a 3" (75mm) pure titanium diaphragm. Since the FX15 is likely to be used in larger rooms than the FX12, its Coaxial Differential Dispersion pattern combines wide coverage close-up with increased output projected to the rear of the audience.

The FX15's grille is a spring-fit into the sides of the enclosure and requires no fixing screws, allowing for easy removal to access and rotate the coaxial driver. The attractive, curved enclosure is manufactured from a rigid composite material with a plywood speaker baffle, and coated in textured black paint.



B18 SUBWOOFER

The B18 is a compact, high performance subwoofer for use with the FX10, FX12 or FX15. It extends the low frequency operating range of the combined system to 40Hz and provides exceptional low frequency impact. It features a long-excursion 18" (460mm)/4" (100 mm) voice coil driver with a water-resistant cone and triple roll surround in a compact reflex enclosure. The design of the 18" driver maximises output while minimising power compression and distortion, and the four reflex ports have a large frontal area to reduce turbulent air noise at very high levels.

The B18 enclosure is constructed from high-density MDF and finished in textured black paint. A perforated steel grille protects the driver and is pre-curved to withstand physical damage.



B218 SUBWOOFER

The B218 achieves the ultimate in subwoofer performance for the most prestigious Blackline 3 applications – delivering very high output levels and superb transient performance with minimal distortion. With an operating range of 35-150Hz, it houses dual 18" long-excursion (460mm)/4" (100mm) voice coil drivers with water-resistant cones and triple roll surrounds. Each driver is rated to handle 1000 watts AES, and has a magnet structure and suspension engineered for maximum linear excursion.

The enclosure of the B218 is constructed from high-density MDF and coated with a textured black finish. Eight reflex ports provide a large frontal area to reduce turbulent air noise, and a perforated steel grille protects the driver from damage with minimal obstruction of airflow.



SYSTEM CONTROL

Designed as full-range passive systems, the FX10, FX12 and FX15 may be used without a controller. However, the EQ and limiter functions of a controller such as the Martin Audio DX1.5 or DX2 will maximise their capabilities. When a B18 or B218 subwoofer is used with an FX10, FX12 or FX15 Blackline 3 coaxial system, crossover and EQ functions can be performed by the DX1.5 and DX2 system controllers, or by an MA Series amplifier with onboard DSP option.





TECHNICAL SPECIFICATIONS

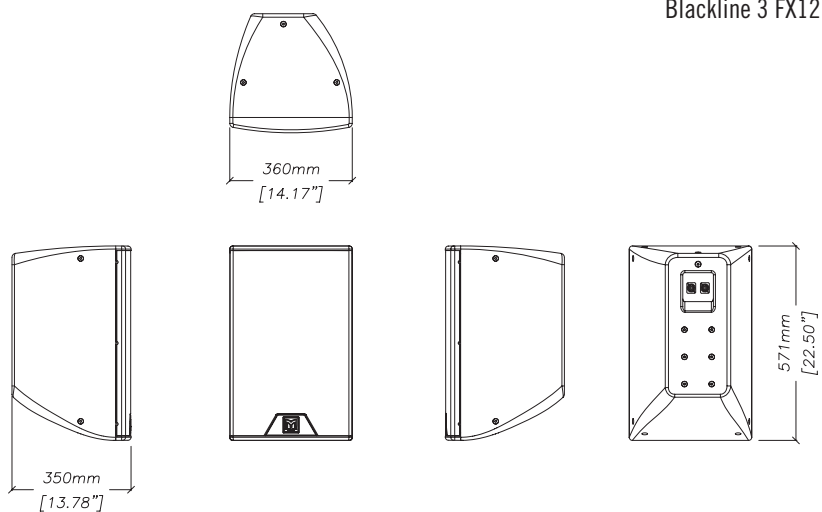
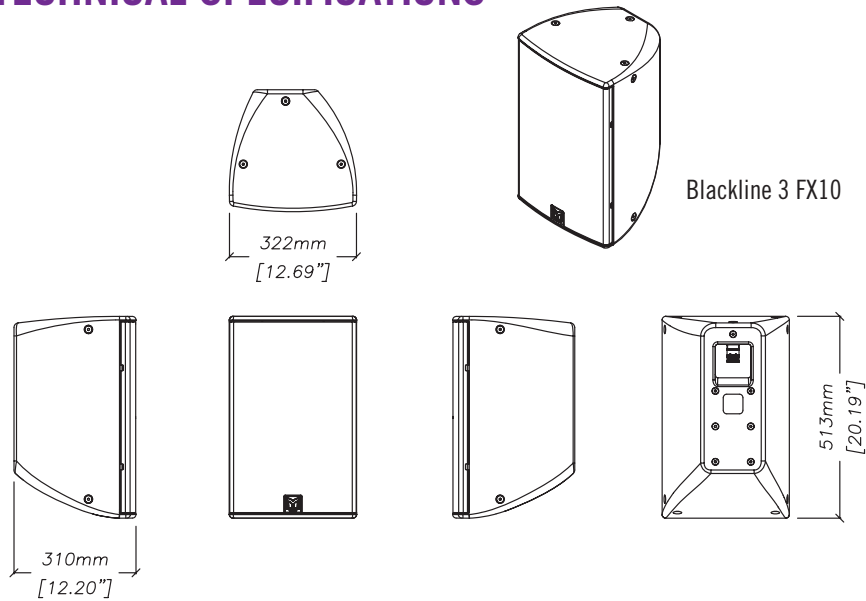

FX10

TYPE	Ultra-compact, Coaxial Differential Dispersion passive two-way system
FREQUENCY RESPONSE (5)	65Hz-20kHz \pm 3dB -10dB @ 45Hz
DRIVER	LF: 10" (250mm)/2.5" (63.5mm) voice coil, long excursion, shared ferrite motor system with HF HF: 1" (25mm) exit/1.4" (38mm) voice coil, polyimide dome compression driver
RATED POWER (2)	250W AES, 1000W peak
RECOMMENDED AMPLIFIER	MA2.0
SENSITIVITY (6)	96dB
MAXIMUM SPL (7)	120dB continuous, 126dB peak
NOMINAL IMPEDANCE	8 ohms
DISPERSION (-6dB)	110°-75° horizontal, 60° vertical (user-rotatable)
CROSSOVER	2kHz passive
ENCLOSURE	28 litre, composite material
FINISH	Black textured paint
PROTECTIVE GRILLE	Black perforated steel, Declon® backed
CONNECTORS	2 x Neutrik® NL4
PIN CONNECTIONS	Input: 1+, 1- Link through: 2+, 2-
FITTINGS	16 x M8 threaded inserts
DIMENSIONS	(W) 323mm x (H) 515mm x (D) 311mm (W) 12.7ins x (H) 20.3ins x (D) 12.2ins
WEIGHT	15.3kg (33.7lbs)

FX12

TYPE	Ultra-compact, Coaxial Differential Dispersion passive two-way system
FREQUENCY RESPONSE (5)	62Hz-20kHz \pm 3dB -10dB @ 50Hz
DRIVER	LF: 12" (300mm)/2.5" (63.5mm) voice coil, long excursion, shared ferrite motor system with HF HF: 1" (25mm) exit/1.7" (44mm) voice coil, polyimide dome compression driver
RATED POWER (2)	300W AES, 1200W peak
RECOMMENDED AMPLIFIER	MA2.0, MA3.0, MA5.2K
SENSITIVITY (6)	97dB
MAXIMUM SPL (7)	122dB continuous, 128dB peak
NOMINAL IMPEDANCE	8 ohms
DISPERSION (-6dB)	110°-60° horizontal, 60° vertical (user-rotatable)
CROSSOVER	1.9kHz passive
ENCLOSURE	38 litre, composite material
FINISH	Black textured paint
PROTECTIVE GRILLE	Black perforated steel, Declon® backed
CONNECTORS	2 x Neutrik® NL4
PIN CONNECTIONS	Input: 1+, 1- Link through: 2+, 2-
FITTINGS	16 M8 threaded inserts
DIMENSIONS	(W) 357mm x (H) 571mm x (D) 348mm (W) 14.1ins x (H) 22.5ins x (D) 13.7ins
WEIGHT	19.5kg (42.5lbs)

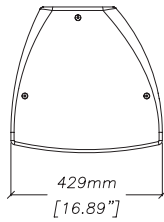

Blackline 3 FX15

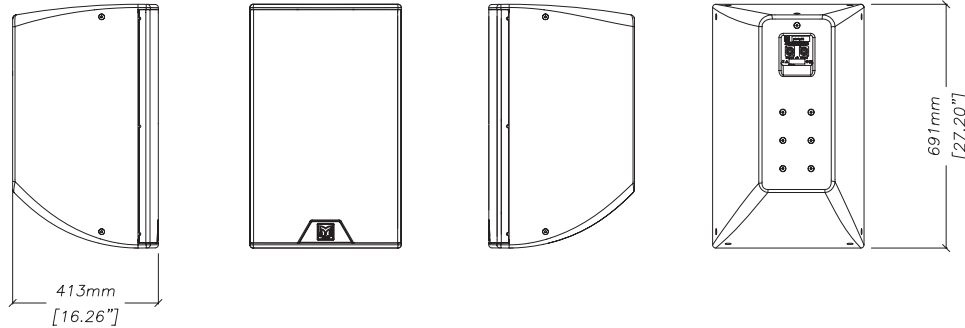

Blackline 3 FH3

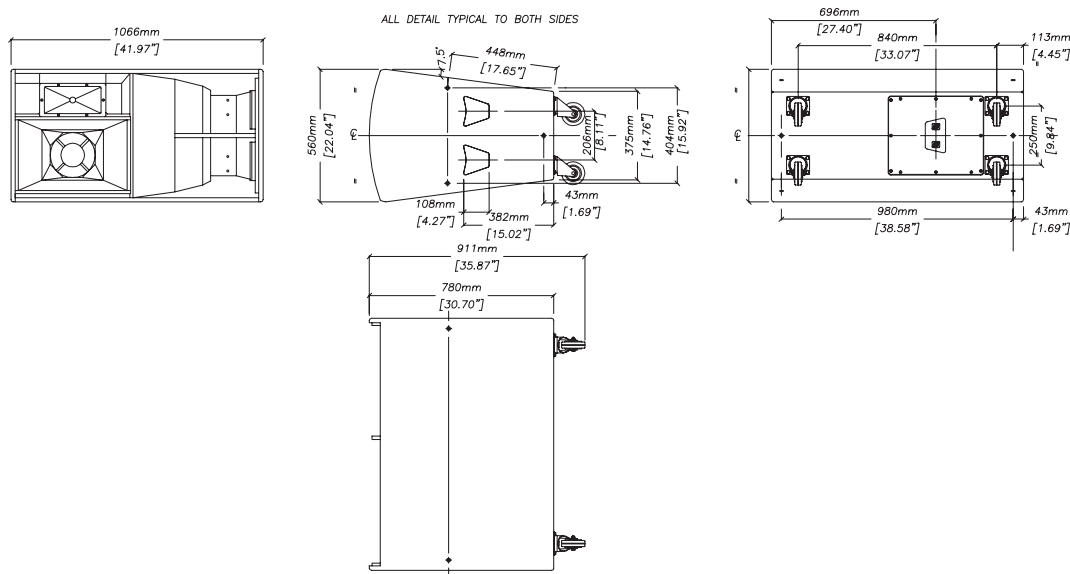

FX15

TYPE	Ultra-compact, Coaxial Differential Dispersion passive two-way system
FREQUENCY RESPONSE (5)	55Hz-18kHz \pm 3dB -10dB @ 45Hz
DRIVER	LF: 15" (380mm)/3" (75mm) voice coil, long excursion, shared ferrite motor system with HF HF: 1.4" (36mm) exit/3" (75mm) voice coil, titanium dome compression driver
RATED POWER (2)	400W AES, 1600W peak
RECOMMENDED AMPLIFIER	MA2.0, MA3.0, MA5.2K
SENSITIVITY (6)	100dB
MAXIMUM SPL (7)	126dB continuous, 132dB peak
NOMINAL IMPEDANCE	8 ohms
DISPERSION (-6dB)	100°-60° horizontal, 60° vertical (user-rotatable)
CROSSOVER	1.6kHz passive
ENCLOSURE	68 litre, composite material
FINISH	Black textured paint
PROTECTIVE GRILLE	Black perforated steel, Declon® backed
CONNECTORS	2 x Neutrik® NL4
PIN CONNECTIONS	Input: 1+, 1- Link through: 2+, 2-
FITTINGS	10 x M8 threaded inserts
DIMENSIONS	(W) 425mm x (H) 691mm x (D) 411mm (W) 16.7ins x (H) 27.2ins x (D) 16.2ins
WEIGHT	27.7kg (61lbs)

FH3

TYPE	Three-way, bi-amp trapezoid, Hybrid® fully horn loaded
FREQUENCY RESPONSE (5)	48Hz-18kHz \pm 3dB
DRIVERS	15" (380mm)/4" (100mm) coil bass driver 10" (250mm)/2.5" (63.5mm) coil mid driver 1" (25mm) exit HF compression driver
RATED POWER (2)	LF: 1000W AES, 4000W peak MF + HF: 300W AES, 1200W peak
RECOMMENDED AMPLIFIER	LF: MA5.2K MF + HF: MA2.0
SENSITIVITY (6)	LF: 104dB, MF + HF: 104dB
MAXIMUM SPL (9)	134dB continuous, 140dB peak
NOMINAL IMPEDANCE	LF: 8 ohms, MF + HF: 8 ohms
DISPERSION (-6dB)	70° horizontal, 40° vertical
CROSSOVER	200Hz active, 2kHz passive
ENCLOSURE	250 litre, multi-laminate birch ply
FINISH	Black textured paint
PROTECTIVE GRILLE	Black perforated steel
CONNECTORS	2 x Neutrik® NL4
PIN CONNECTIONS	LF: 1+, 1- MF + HF: 2+, 2-
FITTINGS	12 x M10 inserts, 4 x 4" (100mm) castors 4 x pocket handles
DIMENSIONS	(W) 1066mm x (H) 560mm x (D) 780mm* (W) 42ins x (H) 22ins x (D) 30.7ins* * 911mm (35.9ins) with wheels
WEIGHT	79kg (174.2lbs)

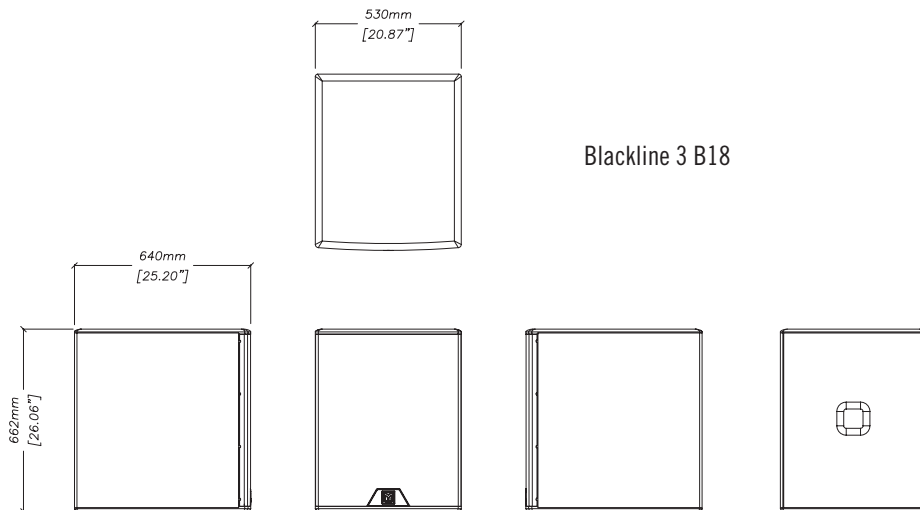

Blackline 3 B18

B18

TYPE	Compact, direct radiating subwoofer
FREQUENCY RESPONSE (1)	40Hz-150Hz ± 3dB -10dB @ 35Hz
DRIVER	18" (460mm)/4" (100mm) voice coil, long excursion, ferrite magnet, waterproof cone
RATED POWER (2)	1000W AES, 4000W peak
RECOMMENDED AMPLIFIER	MA3.0, MA5.2K, MA9.6K, MA12K
SENSITIVITY (3)	102dB
MAXIMUM SPL (9)	132dB continuous, 138dB peak
NOMINAL IMPEDANCE	8 ohms
DISPERSION (-6dB)	Omnidirectional
CROSSOVER	80-120Hz active
ENCLOSURE	160 litre, high-density MDF
FINISH	Black textured paint
PROTECTIVE GRILLE	Black perforated steel
CONNECTORS	2 x Neutrik® NL4
PIN CONNECTIONS	Input: 1+, 1- Link through: 2+, 2-
DIMENSIONS	(W) 530mm x (H) 662mm x (D) 640mm (W) 20.9ins x (H) 26.1ins x (D) 25.2ins
WEIGHT	42kg (93lbs)

B218

TYPE	Dual-driver, direct radiating subwoofer
FREQUENCY RESPONSE (1)	35Hz-150Hz ± 3dB -10dB @ 30Hz
DRIVER	2x18" (460mm)/4" (100mm) voice coil, long excursion, ferrite magnet, waterproof cone
RATED POWER (2)	2000W AES, 8000W peak
RECOMMENDED AMPLIFIER	MA3.0, MA5.2K, MA9.6K, MA12K
SENSITIVITY (3)	105dB
MAXIMUM SPL (9)	138dB continuous, 144dB peak
NOMINAL IMPEDANCE	4 ohms
DISPERSION (-6dB)	Omnidirectional
CROSSOVER	80-120Hz active
ENCLOSURE	330 litre, birch ply
FINISH	Black textured paint
PROTECTIVE GRILLE	Black perforated steel
CONNECTORS	2 x Neutrik® NL4
PIN CONNECTIONS	Input: 1+, 1- and 2+, 2-
FITTINGS	Four pocket handles
DIMENSIONS	(W) 1085mm x (H) 530mm x (D) 780mm* (W) 42.7ins x (H) 20.9ins x (D) 30.7ins* *905mm (35.6ins) with wheels
WEIGHT	84kg (185lbs)

Notes

- (1) Measured on-axis in half space at 2 metres, then referred to 1 metre.
- (2) AES Standard ANSI S4.26-1984.
- (3) Measured in half space at 2 metres with 1 watt input, using band limited pink noise, then referred to 1 metre.
- (4) Measured in half space at 2 metres using band limited pink noise, then referred to 1 metre.
- (5) Measured on-axis in open (4π) space at 2 metres, then referred to 1 metre.
- (6) Measured in open (4π) space at 2 metres with 1 watt input, using band limited pink noise, then referred to 1 metre.
- (7) Measured in open (4π) space at 2 metres using band limited pink noise, then referred to 1 metre.
- (8) Measured in open (4π) space at 2 metres with 2.83v input, using band limited pink noise, then referred to 1 metre.
- (9) Calculated in half space at 1 metre.

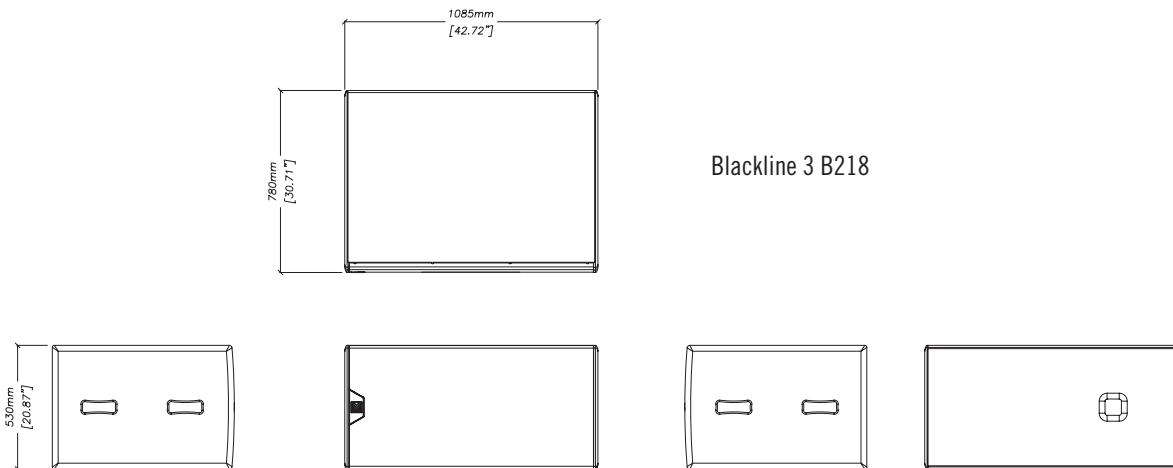

Blackline 3 B218

Martin Audio Limited

Century Point

Halifax Road

Cressex Business Park

High Wycombe

Buckinghamshire

HP12 3SL

England

FOR SALES ENQUIRIES:

UK

Telephone: +44 (0)1494 535312

E-mail: info@martin-audio.com

All information is Copyright © 2015 Martin Audio Ltd.

Martin Audio, the Martin Audio logo and Hybrid are registered trademarks of Martin Audio Ltd. in the United Kingdom, United States and other countries; all other Martin Audio trademarks are the property of Martin Audio Ltd.

www.martin-audio.com

Unite Your Audience
The Martin Audio Experience



Version 2.0