

CDD12-WR

Compact Coaxial Differential Dispersion System - Weatherised



Features

- Compact, CDD™ passive two-way system
- Coaxial Differential Dispersion™ technology
- Elegant UPM Formi composite enclosure
- Outdoor operation when sheltered from direct exposure to elements
- Operating temperature -20°C to +70°C
- Environmentally tested to meet IP54
- User-rotatable coaxial drive unit
- Vertical and horizontal mounting options
- Screw-free water and particle resistant grille
- 8Ω nominal impedance
- Integral inserts for eyebolt suspension
- Discreet weatherised mounting accessories
- Black or white standard colour options

Applications

- Outdoor restaurants, bars, hotel areas
- Nearfield systems in outdoor stadia, transport hubs, concourses and theme parks



The CDD12-WR is a weatherised compact, passive two-way system designed for installations that require high output levels suitable for outdoor applications where it will be subject to changing environmental conditions, but sheltered from direct exposure to the elements. Its high-specification 12" (300mm) LF /1" exit HF Coaxial Differential Dispersion driver delivers perfect sound across the audience over medium-throw distances. It features a water and particle resistant grille made from zinc plated mild steel with powder coated finish and is suitable for operating temperatures between -20°C to +70°C and environmentally tested to meet IP54.

The Coaxial Differential Dispersion technology employed in the CDD12-WR delivers more consistent audience coverage than systems with fixed X° x Y° coverage patterns — projecting relatively more output to the rear of the audience, while having wide horizontal coverage close-up. Its innovative CDD driver achieves 'point source' summation of the LF and HF sections — eliminating off-axis variations in frequency response associated with non-coaxial designs. Improving on conventional coaxial designs, which can suffer from high-frequency beaming, the driver features a static waveguide that merges seamlessly with the unique cone shape — maintaining the dispersion pattern out to very high frequencies.

The LF driver has a 2.5" (65mm) voice coil and efficient motor with an aluminium demodulating ring to minimise distortion, while the HF driver utilises a 1.75" (44mm) polyimide diaphragm and features a low-compression phase-plug to reduce non-linearity.

The visually-distinctive composite enclosure can be used in either horizontal (landscape) or vertical (portrait) orientation, with rotation of the driver easily accomplished by removing the screw-free, protective grille. The curved shape of the CDD12-WR allows it to be surface-mounted close to a wall via an optional wall bracket or suspended from a ceiling by eyebolts or a horizontal yoke option. A full suite of weatherised accessories are available and fixings on the loudspeaker are stainless steel.

Finished in black (RAL9005) or white (RAL9016) as standard.

A full-range, passive two-way system, the CDD12-WR may be used without a controller. However, the EQ and limiter functions of a controller such as the Martin Audio DX0.5, DX1.5 or DX2, or an MA Series amplifier with onboard DSP will maximise its capabilities. When used with a CSX subwoofer, crossover and EQ functions can either be performed by the DX0.5, DX1.5 and DX2 system controllers, or by an iKON or MA Series amplifier with onboard DSP option.

CDD 12-WR

Compact Coaxial Differential Dispersion System - Weatherised



Technical Specifications

Acoustical

TYPE	Compact, high-output, Coaxial Differential Dispersion passive two-way system
FREQUENCY RESPONSE (5)	62Hz-20kHz \pm 3dB -10dB @ 50Hz
DRIVER	LF: 12" (300mm)/2.5" (63.5mm) voice coil, long excursion, shared ferrite motor system with HF HF: 1" (25mm) exit/1.7" (44mm) voice coil, polyimide dome compression driver
RATED POWER (2)	300W AES, 1200W peak
RECOMMENDED AMPLIFIER	iK81, MA2.0
SENSITIVITY (8)	97dB
MAXIMUM SPL (9)	122dB continuous, 128dB peak
NOMINAL IMPEDANCE	8 ohms
DISPERSION (-6dB)	110°-60°horizontal, 60° vertical (user-rotatable)
CROSSOVER	1.9kHz passive
ENCLOSURE	38 litre, composite material
FINISH	Black or white as standard
PROTECTIVE GRILLE	Zinc plated mild steel with powder coated finish and weatherised backing
ENVIRONMENTAL	Rated at IP54
CONNECTORS	Low profile 20A push-lock, weatherproof input panel cover with cable gland
PIN CONNECTIONS	Left to right: Input+, Input -, Link -, Link+
FITTINGS	6 x M8 inserts for wall bracket 10 x M8 fly points
DIMENSIONS	(W) 360mm x (H) 571mm x (D) 350mm (W) 14.2ins x (H) 22.5ins x (D) 13.8ins
WEIGHT	19.8kg (43.65lbs)
ACCESSORIES	CDDWB10/12B wall bracket black CDDWB10/12W wall bracket white CDDYA12B yoke assembly black CDDYA12W yoke assembly white

Notes

- (1) Measured on-axis in half (2pi) space at 2 metres, then referred to 1 metre.
- (2) AES Standard ANSI S4.26-1984.
- (3) Measured in half (2pi) space at 2 metres with 1 watt input, using band limited pink noise, then referred to 1 metre.
- (4) Measured in half (2pi) space at 2 metres using band limited pink noise, then referred to 1 metre.
- (5) Measured on-axis in open (4pi) space at 2 metres, then referred to 1 metre.
- (6) Measured in open (4pi) space at 2 metres with 1 watt input, using band limited pink noise, then referred to 1 metre.
- (7) Measured in open (4pi) space at 2 metres using band limited pink noise, then referred to 1 metre.
- (8) Measured in open (4pi) space at 2 metres with 2.83V input, using band limited pink noise, then referred to 1 metre.
- (9) Calculated at 1 metre.
- (10) Measured in half (2pi) space at 2 metres with 2.83V input, using band limited pink noise, then referred to 1 metre.

Trade Descriptions Act

Due to Martin Audio's policy of continuing improvement, we reserve the right to alter these specifications without prior notice. Martin Audio is committed to refining state of the art sound reinforcement, combining in-depth product and field applications research with advanced manufacturing techniques. Every Martin Audio product is built to the highest manufacturing standards and rigorously tested to ensure that it meets the performance criteria specified in the design.

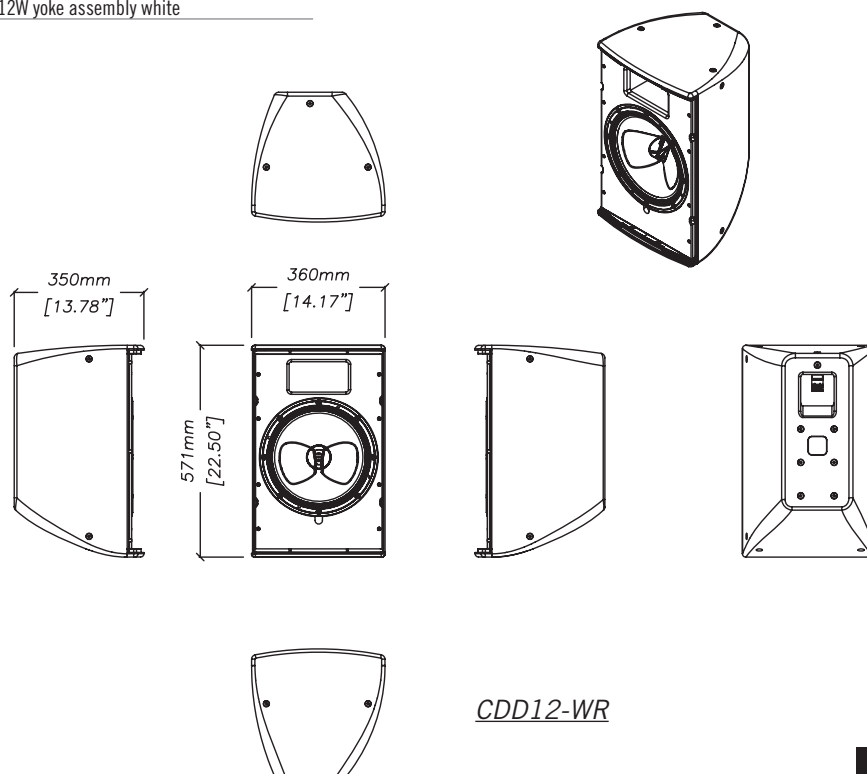

CDD12-WR