

CSX-LIVE 218

Dual-Driver, Direct Radiating Powered Subwoofer



Features

- Dual-driver, self-powered subwoofer
- 2 x 18" (460mm) drivers with 4" (100mm) voice coils
- Very high output capability
- Onboard Class D amplification and DSP
- Dante™ Digital Audio networking
- Global mains operation with Power Factor Correction
- Tour-grade plywood enclosure with flying inserts
- IP24 rating option with rain cowl

Applications

- Live sound reinforcement
- Theatre sound
- Corporate AV events
- Fixed installations in concert halls, ballrooms and HoW
- Bars and clubs



The CSX-LIVE 218 achieves the ultimate in subwoofer performance for the most demanding professional applications – delivering very high output levels and superb transient performance with minimal distortion. With an operating range of 35Hz-150Hz ± 3dB, it houses dual 18" long-excursion (460mm)/4" (100mm) voice coil drivers with water-resistant cones and triple roll surrounds. The design of the 18" drivers maximises output while minimising power compression and distortion, and the eight reflex ports have a large frontal area to reduce turbulent air noise at very high levels. With a prodigious maximum SPL capability of 143dB peak at 1 metre, the CSX-LIVE 218 is the ideal subwoofer for touring sound reinforcement, theatre and portable live sound applications — as well as premium installations — that require low frequency augmentation with low distortion at very high output levels.

A self-powered system, the CSX-LIVE 218 incorporates a Class D amplifier, DSP and Dante™ digital audio networking — simplifying set-up, enhancing control and eliminating amplifier racks. The onboard amplifier delivers a total of 4000W peak output to the drivers, and its switched-mode power supply auto-

ranges to global mains voltages from 100 to 240V 50/60Hz. DSP functions — including parametric EQ, delay, muting, gain and preset selection — can be controlled over Ethernet from a PC or Windows® tablet via intuitive VU-NET™ proprietary software.

For simple set-ups, 'plug-and-play' presets for operation with the CDD-LIVE 8, 12 or 15 — as well as a user-defined preset — can be selected on the rear panel, instead of using computer control. Additional presets provide the appropriate settings for the rear-facing subwoofer in a cardioid pair.

As an alternative to its analogue inputs, the CSX-LIVE 218 is Dante enabled for digital audio distribution and control over a single CAT5 cable to maintain audio quality however long the cable run.

The enclosure is constructed from multi-laminate plywood with a durable polyurea coating and equipped with a perforated steel grille, four grab handles, skids and M10 flying inserts.

CSX-LIVE 218

Dual-Driver, Direct Radiating Powered Subwoofer



Technical Specifications

Acoustics

TYPE	Dual-driver, direct radiating powered subwoofer
FREQUENCY RESPONSE(3)	35Hz – 150Hz ±3dB, -10dB @ 30Hz
DRIVER	2x 18" (460mm)/4" (100mm) voice coil, long excursion, ferrite magnet, waterproof cone
INPUT SENSITIVITY	-20dBu for 100dB SPL (CDD12/15 pre-set) -13dBu for 100dB SPL (CDD8 pre-set)
MAXIMUM SPL (4)	140dB continuous / 143dB peak
DISPERSION	Omnidirectional / or Cardioid (paired)
CROSSOVER	Active Presets for CDD Live 8, 12 & 15 mono-pole or cardioid (paired)

Module

Audio input

CONNECTORS	Female XLR input, male XLR link output, Dante Audio Neutrik® Ethercon
ANALOGUE INPUT IMPEDANCE	20 kΩ balanced to ground
MAXIMUM ANALOGUE INPUT LEVEL	24.6 Vpp (+21dBu), over voltage protected

Internal Processing

	Multi-channel DSP, programmable via TCP/IP using VU-Net software
	PEQ/shelving filters
	Up to 48dB/Oct LPF
	Up to 200mS input delay
	Pre-set selection via rear panel switch

Network

CONNECTORS	2xNeutrik® EtherconRJ45
PROTOCOL	TCP/IP and UDP/IP

Amplifier Module

TYPE	Two 2 channel switch-mode, class D, Bridged Tied Load
PEAK OUTPUT POWER	4000W
CONTINUOUS OUTPUT POWER	2000W
AVERAGE EFFICIENCY	89%
COOLING	External fan
MAXIMUM AMBIENT TEMPERATURE	40°C (104°F) for full output

Power Supply

TYPE	Switch mode, fixed frequency with PFC
AC INPUT OPERATING RANGE	85 – 265V ~ AC, 50 – 60Hz
POWER FACTOR	> 0.98
NOMINAL POWER CONSUMPTION	550W
MAINS CONNECTOR	Neutrik® Powercon True1

Mechanical

ENCLOSURE	Extensively braced multi-laminate birch plywood
FINISH	Textured black PU coating
PROTECTIVE GRILLE	HEX perforated mild steel with protective zinc plating and black powder coat finish

FITTINGS	Two skids on base, with mating channels on top Four rear-mounted 100mm (4in) castors 24 x M10 mounting points 4x Bar handles, 2 on each side 4x fittings for optional transit cover Optional weather protection cowl
----------	---

IP RATING	IP24 factory option available
DIMENSIONS	(W) 1085mm x (H) 537mm x (D) 792mm (920mm including castors) (W) 42.72in x (H) 21.13in x (D) 31.16in (36.20in including castors)
WEIGHT	105kg (231lbs) excluding Transit cover
ACCESSORIES	Transit Cover

Notes

- (1) Measured on-axis in free space (4 π space) at 2 metres, then referred to 1 metre
- (2) Measured in free space at 1 metre with a tone burst signal
- (3) Measured on-axis on ground plane (2 π space) at 2 metres, then referred to 1 metre
- (4) Measured in half-space at 1 metre with a tone burst signal

Trade Descriptions Act

Due to Martin Audio's policy of continuing improvement, we reserve the right to alter these specifications without prior notice. Martin Audio is committed to refining state of the art sound reinforcement, combining in-depth product and field applications research with advanced manufacturing techniques. Every Martin Audio product is built to the highest manufacturing standards and rigorously tested to ensure that it meets the performance criteria specified in the design.

Architectural Specifications

The loudspeaker shall be a self-powered subwoofer consisting of two 18" reflex-loaded, long-excursion, low frequency transducers. The on-axis frequency response shall be 35Hz-150kHz +/- 3dB and the loudspeaker shall produce a maximum SPL of 143dB peak at 1 metre.

The loudspeaker shall incorporate a Class D amplifier module which shall deliver a total of 4000W peak output to the transducers and include onboard DSP and networking capabilities for remote control and monitoring. The loudspeaker shall be Dante™ enabled for Audio over IP. Its power supply shall employ Power Factor Correction and operate from 100-240V, 50-60Hz AC.

Audio connectors shall be male and female XLR type and the AC power connector shall be a Neutrik® Powercon True1. Network connectors shall be Neutrik® Ethercon RJ45 type.

The loudspeaker enclosure shall be constructed from multi-laminate plywood with a textured polyurea coating. The drivers shall be protected by a perforated steel grille and the enclosure shall be fitted with grab handles, skids and flying inserts.

An IP24 rating version with a rain cowl shall be available as a factory option.

Dimensions excluding castors (W x H x D) shall be 1085mm x 537mm x 792mm (42.7in x 21.1in x 31.2in). Dimensions including castors (W x H x D) shall be 1085mm x 537mm x 920mm (42.7in x 21.1in x 36.2in). Weight shall be 105kg (231lbs).

The loudspeaker shall be the Martin Audio CSX-LIVE 218.

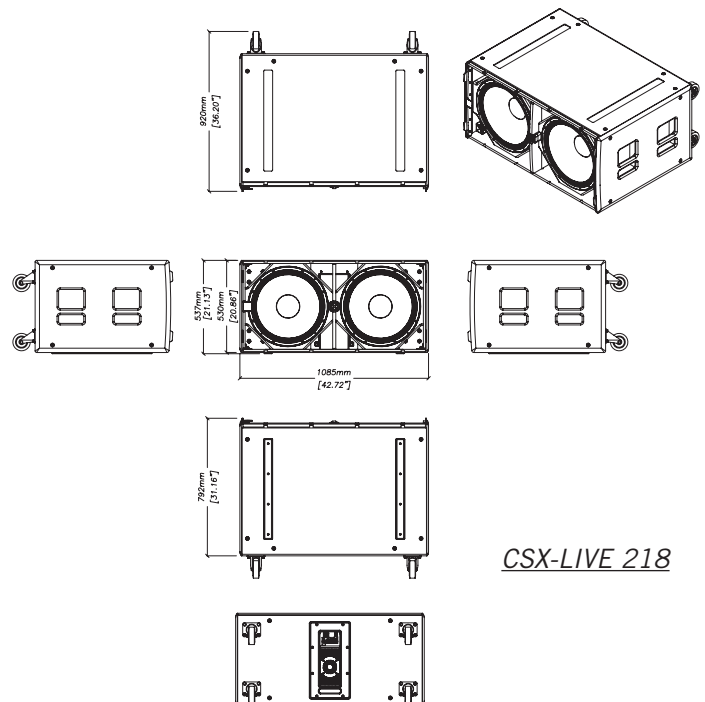

CSX-LIVE 218

Martin Audio Ltd
Century Point, Halifax Road, High Wycombe
Buckinghamshire HP12 3SL, England

Telephone: +44 (0) 1494 535 312
Email: info@martin-audio.com

All information is Copyright © 2016 Martin Audio Ltd.

www.martin-audio.com

