

FP12



12" Compact Point Source Loudspeaker

Features

- Compact, passive two-way loudspeaker
- Versatile, multi-angle enclosure
- High output capability
- Coaxial Point Source configuration with user-rotatable drive unit
- 12" (300mm)/3" (75mm) voice coil low distortion neodymium LF driver
- 3" (75mm) titanium diaphragm/1.4" (35mm) exit HF driver
- 90° H x 60° V dispersion
- Quick-release steel grille
- 3D prediction software [DISPLAY 3]
- Powered by iKON or VIA amplifiers

Applications

- Portable live sound reinforcement
- Theatre sound
- Fixed installations
- DJ and corporate AV events
- High-power stage monitoring

The FP12 is a premium, point-source loudspeaker designed for short-throw applications which require superb sonic performance, high output, and coverage consistency from a compact enclosure. Its small size and portability extend its range of applications from live sound and permanent installations to corporate events, gigging musicians and DJ's.

With a multi-angle enclosure and a wide range of mounting options, the FP12 is the perfect high-power solution for rental companies and professional applications which benefit from flexibility and speed of deployment.

When supplemented by a subwoofer, it is an excellent choice for premium, short-throw corporate AV events and music playback systems. It can also be used as a high output stage monitor, or in conjunction with a larger touring or installed sound system.

The FP12 is a two-way passive loudspeaker featuring a high-specification 12" LF driver and a 1.4" exit HF driver with a 3" diameter titanium diaphragm. It delivers an impressive maximum SPL of 128dB peak and has a well-defined dispersion pattern of 90° horizontal x 60° vertical, with horizontal constant directivity characteristics.



Its exemplary coverage pattern is achieved by incorporating a dedicated waveguide within the magnet structure which merges into a specially contoured LF cone. With the waveguide and cone combining to form the HF horn, this innovative arrangement avoids a separate 'add-on' horn which would impede the wavefront from the cone and cause irregularities in the frequency response. It also improves on conventional through-the-pole coaxial designs, which can suffer from high frequency beaming.

The FP12's durable birch plywood enclosure is finished in hardwearing textured paint and incorporates multiple threaded inserts to cater for a wide range of mounting options and accessories — including yoke, wall bracket and truss mounting. A dual pole-mount socket with 0° and 15° down-tilt angles is incorporated into the base of the enclosure, and twin handles aid installation and deployment. A steel grille with a triple-layer polyester backing presents a discreet, professional appearance, while resisting dust and water ingress to IP54 environmental rating.

The FP12 can be used in either portrait or landscape orientation by rotating the driver within the enclosure. To make this operation quick and easy, the grille is secured by proprietary quick-release latches, and the driver fixed to the baffle by means of captive release clamps. Loosening these by hand allows the driver to be quickly rotated through 90° and re-tightened.

FP12 can be powered by iKON amplifiers, or by VIA amplifiers when used with a DX4.0 controller, or alternatively a DX0.4 or DX0.6 controller. FP12 systems can be modelled in 3D using Display 3 design and prediction software.

FP12



12" Compact Point Source Loudspeaker

Technical Specifications

PRODUCT NAME	FP12
TYPE	Coaxial passive 2-way
CROSSOVER FREQUENCY	1.5kHz
FREQUENCY RESPONSE - 4π (5)	55Hz - 20kHz ± 3dB, -10dB @44Hz with preset
DRIVERS	LF: 12", 3" Voice coil, Neodymium Motor with flux stabilising rings HF: 1.4" exit, 3" Voice coil, Coaxial titanium dome compression driver
SENSITIVITY (2.83V 1m free-field)	97dB
NOMINAL IMPEDANCE	8 Ohms
RATED POWER	350W AES, 1400W peak
MAXIMUM SPL	122dB Cont, 128dB Peak (6dB)
DISPERSION (-6dB)	90° H, 60° V
CONNECTORS	NLT4MPXX-BAG speakons (pair)
PIN CONNECTIONS (INPUT)	1+ / 1-
PIN CONNECTIONS (LINK)	1+/- and 2+/-
FITTINGS	4 x M10, 17 x M8 fixing points, dual pole-mount socket, 2 x handle pockets
DIMENSIONS	(W) 521mm, (H) 390mm, (D) 346mm (W) 20.5ins, (H) 15.4ins, (D) 13.6ins
WEIGHT	17.5kg (38.6lbs)
VOLUME	33.5L
ACCESSORIES	Separate landscape and portrait touring and install yokes, wall bracket, rigging bar and transit cover

Notes

- (1) Measured on-axis in half (2pi) space at 2 metres, then referred to 1 metre.
- (2) AES Standard ANSI S4.26-1984.
- (3) Measured in half (2pi) space at 2 metres with 1 watt input, using band limited pink noise, then referred to 1 metre.
- (4) Measured in half (2pi) space at 2 metres using band limited pink noise, then referred to 1 metre.
- (5) Measured on-axis in open (4pi) space at 2 metres, then referred to 1 metre.
- (6) Measured in open (4pi) space at 2 metres with 1 watt input, using band limited pink noise, then referred to 1 metre.
- (7) Measured in open (4pi) space at 2 metres using band limited pink noise, then referred to 1 metre.
- (8) Measured in open (4pi) space at 2 metres with 2.83V input, using band limited pink noise, then referred to 1 metre.
- (9) Calculated at 1 metre.
- (10) Measured in half (2pi) space at 2 metres with 2.83V input, using band limited pink noise, then referred to 1 metre.

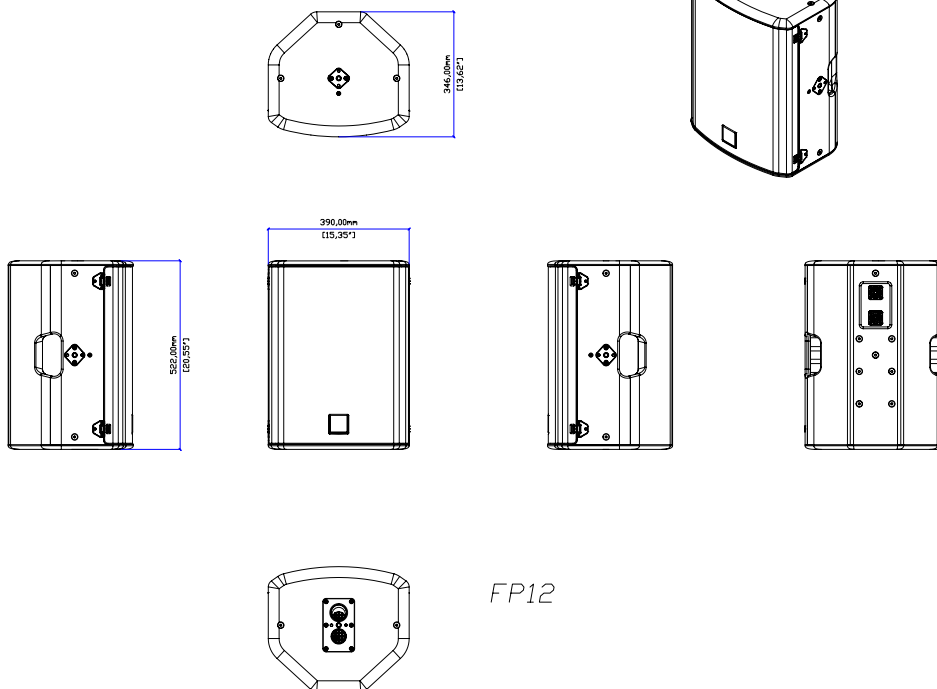

FP12