

FP4



4" Miniature Point Source Loudspeaker

Features

- Miniature, passive two-way loudspeaker
- High output capability relative to size
- Coaxial Point Source configuration
- Wide frequency response for quality speech and music reproduction
- 4" (100mm)/1.25" (32mm) voice coil LF driver
- 1" (25mm) polymer diaphragm/0.7" (18mm) exit HF driver
- 110° conical dispersion
- 3D prediction software [DISPLAY 3]
- Powered by iKON or VIA amplifiers

Applications

- Fill and spot coverage where space is limited
- Theatres and churches requiring minimal visual intrusion
- Distributed systems in bars and restaurants
- Museum and gallery installations
- Immersive sound spaces
- Portable corporate AV events



The FP4 is a point-source loudspeaker designed for short-throw distributed systems which require premium sound quality from a miniature enclosure. It delivers exceptional output and performance for its size and is ideal for installations requiring spot and fill coverage where space is limited. With a wide and smooth frequency response, it reproduces both speech and music effortlessly.

Its miniature size and flexible mounting options, including mic stand, make for discreet integration within any setting — from small stages, churches, museums and galleries to theatres, bars and restaurants. Being both portable and surprisingly powerful for its size, it can also be used for corporate AV events and as a fill loudspeaker within a larger sound system. When supplemented by a subwoofer, it is also an excellent choice for a premium background music system in a wide variety of venues.

The FP4 is a two-way passive design featuring a 4" LF driver and a 0.7" exit HF driver with a 1" diameter high-temperature

polymer dome. It has an impressive maximum SPL of 108dB peak, and its Coaxial Point Source configuration produces a well-defined, conical 110° dispersion pattern which is perfect for close proximity applications.

Its durable birch plywood enclosure is finished in hardwearing textured paint and incorporates threaded inserts for U-bracket, wall bracket and mic stand mounting. A steel grille with a triple-layer polyester backing presents a discreet, professional appearance, while resisting dust and water ingress to IP54 environmental rating.

FP4 can be powered by iKON amplifiers, or by VIA amplifiers when used with a DX4.0 controller, or alternatively a DX0.4 or DX0.6 controller. FP4 systems can be modelled in 3D using Display 3 design and prediction software.

FP4



4" Miniature Point Source Loudspeaker

Technical Specifications

| | |
|--------------------------------|---|
| PRODUCT NAME | FP4 |
| TYPE | Coaxial passive 2-way |
| CROSSOVER FREQUENCY | 2.6kHz |
| FREQUENCY RESPONSE - 4π (5) | 142Hz - 18kHz ± 3dB, -10dB @103Hz with preset |
| DRIVERS | LF: 4", 1.25" Voice coil, Ferrite Motor HF: 0.7" exit, 1" Voice coil, Coaxial HT polymer dome compression driver |
| SENSITIVITY (4V 1m free-field) | 84dB |
| NOMINAL IMPEDANCE | 16 Ohms |
| RATED POWER | 60W AES, 240W peak |
| MAXIMUM SPL | 102dB Cont, 108dB Peak (6dB) |
| DISPERSION (-6dB) | 110° conical |
| CONNECTORS | NL4MPXX speakons (pair), Pheonix terminal block 1725302 |
| PIN CONNECTIONS (INPUT) | 1+ / 1- |
| PIN CONNECTIONS (LINK) | 1+/- and 2+/- |
| FITTINGS | 4 x M6 inserts, 1 x 3/8" (mic stand) fixing point |
| DIMENSIONS | (W) 130mm, (H) 130mm, (D) 126mm (W) 5.1ins, (H) 5.1ins, (D) 5.0ins |
| WEIGHT | 1.9kg (4.2lbs) |
| VOLUME | 0.8L |
| ACCESSORIES | Touring & install yoke |

Notes

- (1) Measured on-axis in half (2pi) space at 2 metres, then referred to 1 metre.
- (2) AES Standard ANSI S4.26-1984.
- (3) Measured in half (2pi) space at 2 metres with 1 watt input, using band limited pink noise, then referred to 1 metre.
- (4) Measured in half (2pi) space at 2 metres using band limited pink noise, then referred to 1 metre.
- (5) Measured on-axis in open (4pi) space at 2 metres, then referred to 1 metre.
- (6) Measured in open (4pi) space at 2 metres with 1 watt input, using band limited pink noise, then referred to 1 metre.
- (7) Measured in open (4pi) space at 2 metres using band limited pink noise, then referred to 1 metre.
- (8) Measured in open (4pi) space at 2 metres with 2.83V input, using band limited pink noise, then referred to 1 metre.
- (9) Calculated at 1 metre.
- (10) Measured in half (2pi) space at 2 metres with 2.83V input, using band limited pink noise, then referred to 1 metre.

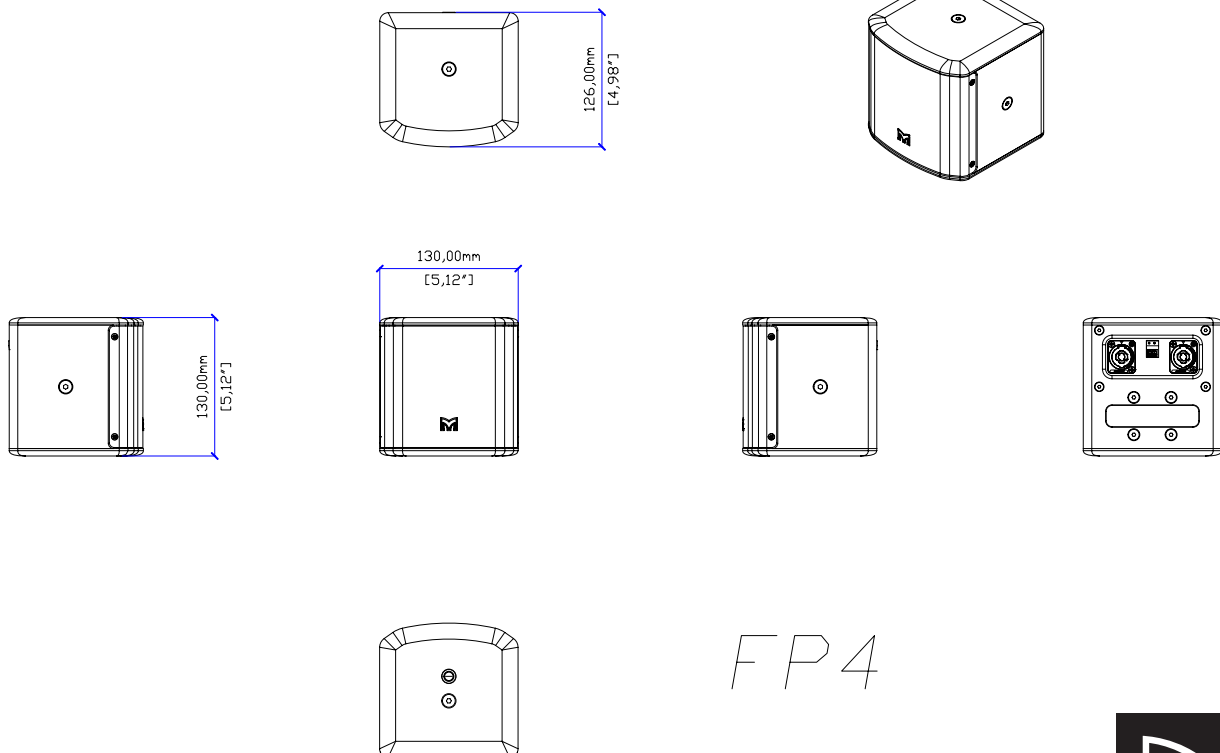

FP4