

# SXP118

## Compact, Direct Radiating Powered Subwoofer

### Features

- Compact, self-powered subwoofer
- 1 x 18" (460mm) driver with 4" (100mm) voice coil
- Onboard Class D amplification and DSP
- Dante™ Digital Audio networking
- Global mains operation with Power Factor Correction
- Tour-grade plywood enclosure with flying inserts
- IP24 rating option with rain cowl

### Applications

- Live sound reinforcement
- Theatre sound
- Corporate AV events
- Fixed installations in concert halls, ballrooms and HoW
- Bars and clubs
- Outdoor restaurant, bar and hotel entertainment areas
- Concourses and Theme Parks

The SXP118 is a compact, high-performance subwoofer that extends the low frequency operating range of a CDD-LIVE full-range system to 40Hz — providing exceptional low frequency impact and increasing headroom. It features a long-excursion 18" (460mm)/4" (100 mm) voice coil driver with a water-resistant cone and triple roll surround in a compact reflex enclosure. The design of the 18" driver maximises output while minimising power compression and distortion, and the four reflex ports have a large frontal area to reduce turbulent air noise at very high levels. With a maximum SPL capability of 135dB peak at 1 metre, the SXP118 is the ideal subwoofer for theatre and portable live sound applications, as well as premium installations that require the maximum output from a compact enclosure.

A self-powered system, the SXP118 incorporates a Class D amplifier, DSP and Dante™ digital audio networking — simplifying set-up, enhancing control and eliminating amplifier racks. The onboard amplifier delivers 2000W peak output to the driver, and its switched-mode power supply auto-ranges to global mains voltages from 100 to 240V 50/60Hz. DSP functions — including parametric EQ, delay, muting, gain and preset selection — can be controlled over Ethernet from a PC or Windows® tablet via intuitive VU-NET™ proprietary software.



For simple set-ups, 'plug-and-play' presets for operation with the CDD-LIVE 8, 12 or 15 — as well as a user-defined preset — can be selected on the rear panel, instead of using computer control. Additional presets provide the appropriate settings for the rear-facing subwoofer in a cardioid pair.

As an alternative to its analogue inputs, the SXP118 is Dante enabled for digital audio distribution and control over a single CAT5 cable to maintain audio quality however long the cable run.

The enclosure is constructed from multi-laminate plywood with a durable polyurea coating and equipped with a perforated Zintec grille, twin grab handles, skids, M10 flying inserts and a threaded pole socket.

The product is supplied as standard without cabinet wheels, but they are available as an accessory.

By adding the input board cover accessory, the subwoofer is fully weather resistant and suitable for permanent outdoor usage.

# SXP118

## Compact, Direct Radiating Powered Subwoofer

### Technical Specifications

<b>Acoustics</b>	
TYPE	Compact, direct radiating powered subwoofer
FREQUENCY RESPONSE (3)	47Hz – 150Hz $\pm$ 3dB, -10dB at 41Hz
DRIVER	18" (460mm)/4" (100mm) voice coil, long excursion, ferrite magnet, waterproof cone
INPUT SENSITIVITY	-20dBu for 100dB SPL (CDD12/15 pre-set) -13dBu for 100dB SPL (CDD8 pre-set)
MAXIMUM SPL (4)	132dB continuous / 135dB peak
DISPERSION	Omnidirectional / or Cardioid (paired)
CROSSOVER	Active Presets for CDD Live 8, 12 & 15 mono-pole or cardioid (paired)
<b>Module</b>	
<b>Audio input</b>	
CONNECTORS	Female XLR input, male XLR link output, Dante Audio Neutrik® Ethercon
ANALOGUE INPUT IMPEDANCE	20 k $\Omega$ balanced to ground
MAXIMUM ANALOGUE INPUT LEVEL	24.6 Vpp (+21dBu), over voltage protected
<b>Dante sample rate</b>	Dante at 48 kHz
<b>Internal Processing</b>	
	Multi-channel DSP, programmable via TCP/IP using VU-Net software
	PEQ/shelving filters
	Up to 48dB/Oct LPF
	Up to 200ms input delay
	Pre-set selection via rear panel switch
<b>Network</b>	
CONNECTORS	2xNeutrik® Ethercon
PROTOCOL	TCP/IP and UDP/IP
<b>Amplifier Module</b>	
TYPE	2 channel switch-mode, class D, Bridged Tied
PEAK OUTPUT POWER	2000W
CONTINUOUS OUTPUT POWER	1000W
AVERAGE EFFICIENCY	89%
COOLING	External fan
MAXIMUM AMBIENT TEMPERATURE	40°C (104°F) for full output
<b>Power Supply</b>	
TYPE	Switch mode, fixed frequency with PFC
AC INPUT OPERATING RANGE	85 – 265V ~ AC, 50 – 60Hz
POWER FACTOR	> 0.98
NOMINAL POWER CONSUMPTION	550W
MAINS CONNECTOR	Neutrik® Powercon True1
<b>Mechanical</b>	
ENCLOSURE	Extensively braced multi-laminate birch plywood.
FINISH	Textured black PU coating.
PROTECTIVE GRILLE	Black perforated Zintec.
FITTINGS	Two skids on base, with mating channels on top 16 x M8 inserts for optional castors M20 top-mounted thread plate for pole mounting 16 x M10 mounting points 2x Bar handles, 1 on each side 4x fittings for optional transit cover 16 x M8 inserts for optional castors
IP RATING	IP24 factory option available
DIMENSIONS	(W) 600mm x (H) 507mm x (D) 632mm (760mm including castors) (W) 23.62in x (H) 20in x (D) 24.86in (29.90in including castors)
WEIGHT	46.5kg(103lbs) w/o castors, 50kg (110lbs) with castors
ACCESSORIES	16 x M8 inserts for optional castors, Input Board Cover, Transit Cover

#### Notes

- (1) Measured on-axis in free space (4 $\pi$  space) at 2 metres, then referred to 1 metre
- (2) Measured in free space at 1 metre with a tone burst signal
- (3) Measured on-axis on ground plane (2 $\pi$  space) at 2 metres, then referred to 1 metre
- (4) Measured in half-space at 1 metre with a tone burst signal

#### Trade Descriptions Act

Due to Martin Audio's policy of continuing improvement, we reserve the right to alter these specifications without prior notice. Martin Audio is committed to refining state of the art sound reinforcement, combining in-depth product and field applications research with advanced manufacturing techniques. Every Martin Audio product is built to the highest manufacturing standards and rigorously tested to ensure that it meets the performance criteria specified in the design.

### Architectural Specifications

The loudspeaker shall be a self-powered subwoofer consisting of a 18" reflex-loaded, long-excursion, low frequency transducer. The on-axis frequency response shall be 47Hz-150Hz  $\pm$ 3dB and the loudspeaker shall produce a maximum SPL of 135dB peak at 1 metre.

The loudspeaker shall incorporate a Class D amplifier module which shall deliver a total of 2000W peak output to the transducer and include onboard DSP and networking capabilities for remote control and monitoring. The loudspeaker shall be Dante™ enabled for Audio over IP. Its power supply shall employ Power Factor Correction and operate from 100-240V, 50-60Hz AC.

Audio connectors shall be male and female XLR type and the AC power connector shall be a Neutrik® Powercon True1. Network connectors shall be Neutrik® Ethercon RJ45 type.

The loudspeaker enclosure shall be constructed from multi-laminate plywood with a textured polyurea coating. The drivers shall be protected by a perforated Zintec grille and the enclosure shall be fitted with a threaded pole-mount plate, grab handles, skids and flying inserts.

An IP24 rating version with an Input Board cover shall be available as a factory option.

Dimensions excluding castors (W x H x D) shall be 600mm x 509mm x 632mm (23.6in x 20in x 24.9in) and weight shall be 46.5kg (103lbs). Dimensions including castors (W x H x D) shall be 600mm x 509mm x 760mm (23.6in x 20in x 29.9in). Weight shall be 50kg (110lbs).

The loudspeaker shall be the Martin Audio SXP118.

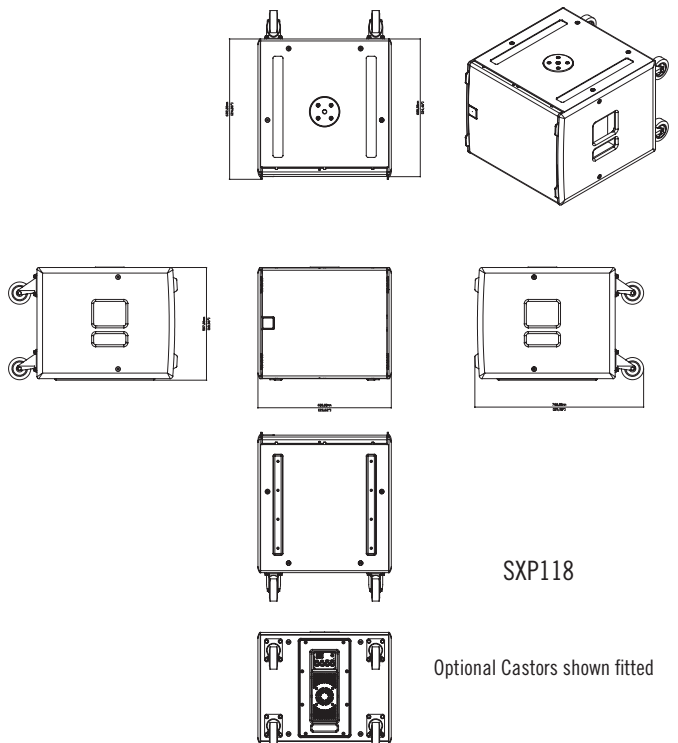

SXP118

Optional Castors shown fitted

Martin Audio Ltd  
Century Point, Halifax Road, High Wycombe  
Buckinghamshire HP12 3SL, England

Telephone: +44 (0) 1494 535 312  
Email: [info@martin-audio.com](mailto:info@martin-audio.com)

All information is Copyright © 2025 Martin Audio Ltd.



[www.martin-audio.com](http://www.martin-audio.com)